



Complementary Safety margin Assessment of the HOR



Complementary Safety margin Assessment

Stress test of the Hoger Onderwijs Reactor

Performed by: NRG
In cooperation with: RID
Ordered by: RID
Date: May 30th 2013
Version: 2.0

Contents

Prologue	13	
Executive Summary	15	
List of abbreviations	21	
Introduction	25	
1	General data of the site/plant	27
1.1	The Reactor Institute Delft	27
1.2	Brief description of the site characteristics	27
1.3	Main characteristics of the unit	30
1.3.1	The reactor	32
1.3.2	The core	34
1.3.3	Fuel storage	36
1.3.4	The reactor cooling system	36
1.3.5	The reactor hall	37
1.3.6	Control room and instrumentation	38
1.3.7	The ventilation system	41
1.3.8	Water clean-up and make-up system	43
1.3.9	The electrical power system	44
1.3.10	Experimental facilities	44
1.3.11	Auxiliary systems	47
1.3.11.1	Fire detection/fighting	47
1.3.11.2	Central Measuring and Registration System (CRS)	47
1.3.11.3	Communication systems	47
1.3.12	Nuclide inventory	48
1.4	Systems for providing or supporting main safety functions	48
1.4.1	Reactivity control	49
1.4.1.1	Reactivity control system of the HOR	49
1.4.1.2	Reactivity control of stored fuel	50
1.4.2	Heat transfer from reactor to the ultimate heat sink	51
1.4.2.1	Existing heat transfer means	51
1.4.2.2	Lay out information on the heat transfer chains	53
1.4.2.3	Possible time constraints for availability of heat transfer chains	54
1.4.2.4	AC power sources and batteries for each chain	54
1.4.2.5	Need and method of cooling equipment	54
1.4.3	Heat transfer from spent fuel pools to the ultimate heat sink	55
1.4.4	Heat transfer from the reactor containment to the ultimate heat sink	55
1.4.4.1	Existing heat transfer means	55
1.4.4.2	Lay out information on the heat transfer chains	55
1.4.4.3	Possible time constraints for availability of heat transfer chains	55
1.4.4.4	AC power sources and batteries for each chain	55
1.4.4.5	Need and method of cooling equipment	56
1.4.5	Confinement of radioactivity	56
1.4.5.1	Existing means of confinement	56
1.4.5.2	Lay out information of the confinement system	56
1.4.5.3	AC power sources and batteries for each chain	57
1.4.5.4	Need and method of confinement	57

1.4.6	AC power supply	58
1.4.6.1	Off-site power supply	58
1.4.6.1.1	Reliability of off-site power supply	58
1.4.6.1.2	Connection of the plant with external power grid	58
1.4.6.2	Power distribution inside the plant	58
1.4.6.2.1	Main cable routings and power distribution switchboards	58
1.4.6.2.2	Lay-out, location, and physical protection against internal and external hazards	58
1.4.6.3	Main ordinary on-site source for back-up power supply	58
1.4.7	Batteries for DC power supply	59
1.4.7.1	Description of separate batteries banks	59
1.4.7.2	Consumers reserved by each battery bank	59
1.4.7.3	Physical location and separation and protection from internal and external hazards	59
1.4.7.4	Alternative possibilities for recharging each battery bank	59
1.5	Scope and main results of Probabilistic Safety Assessments	61
2	Earthquakes	62
2.1	Design basis	62
2.1.1	Earthquake against which the plant is designed	62
2.1.1.1	Back ground	62
2.1.1.2	Characteristics of the design base earthquake (DBE)	65
2.1.1.3	Methodology used to evaluate the design base for the earthquake	66
2.1.1.4	Conclusion on the adequacy of the design base for the earthquake	66
2.1.2	Provisions to protect the plant against the design base earthquake	66
2.1.2.1	SSC's required for achieving safe shutdown state	66
2.1.2.2	Main operating contingencies	68
2.1.2.3	Protection against indirect effects of the earthquake	68
2.1.2.3.1	Assessment of potential failures	68
2.1.2.3.2	Loss of external power supply	70
2.1.2.3.3	Situation outside the plant	70
2.1.2.3.4	Other indirect effects (e.g. fire or explosion)	70
2.1.3	Compliance of the plant with its current licensing basis	70
2.1.3.1	Processes to ensure needed faultless condition	70
2.1.3.2	Processes to ensure mobile equipment preparedness	70
2.1.3.3	Potential deviations from licensing basis	71
2.2	Evaluation of safety margins	71
2.2.1	Range of earthquake leading to severe fuel damage	71
2.2.1.1	Reactor pool	71
2.2.1.1.1	Ground pressure	72
2.2.1.1.2	Pool walls	72
2.2.1.1.3	Eccentric loads on the pile foundation	72
2.2.1.1.4	Falling debris	73
2.2.1.1.5	Stack	73
2.2.1.2	Stability of core configuration	73
2.2.1.3	Stability of storage racks	73
2.2.1.4	Safety of dome crane during an earthquake	73
2.2.2	Range of earthquake leading to loss of containment integrity	74
2.2.3	Earthquake and consequent flooding exceeding design basis	74
2.2.4	Measures to increase robustness of the plant against earthquakes	75

3	Flooding	77
3.1	Flood sources	77
3.1.1	Flooding from the North Sea	77
3.1.1.1	High tide and storm surges	77
3.1.1.2	Tsunami	77
3.1.2	Flooding of the rivers	78
3.1.3	Flooding by water-table	78
3.2	Design base	79
3.2.1	Flooding against which the plant is designed	80
3.2.1.1	Characteristics of the design base flood (DBF)	81
3.2.1.2	Methodology used to evaluate the design base flood	81
3.2.1.3	Conclusion on the adequacy of protection against external flooding	82
3.2.2	Provisions to protect the plant against the design base flood	82
3.2.2.1	SSC's required for achieving safe shutdown state	82
3.2.2.2	Main design and construction provisions to prevent flood impact	84
3.2.2.3	Main operating provisions to prevent flood impact	85
3.2.2.4	Situation outside the plant	85
3.2.3	Plant compliance with its current licensing basis	85
3.2.3.1	Processes to ensure needed faultless condition	85
3.2.3.2	Processes to ensure mobile equipment preparedness	85
3.2.3.3	Potential deviations from licensing basis	85
3.3	Evaluation of safety margins	85
3.3.1	Estimation of safety margin against flooding	85
3.3.2	Measures to increase robustness of the plant against flooding	87
4	Extreme weather conditions	89
4.1	Design basis	89
4.1.1	Reassessment of weather conditions used as design base	89
4.1.1.1	Verification of weather conditions used as designed base	89
4.1.1.2	Postulation of proper specifications for extreme weather conditions	93
4.1.1.3	Assessment of the expected frequency of the design base conditions	94
4.1.1.4	Consideration of potential combination of weather conditions	94
4.1.1.5	Conclusion on the adequacy of protection against extreme weather conditions	94
4.2	The design is sufficient to protect the HOR against the other discussed phenomena. Evaluation of safety margins	95
4.2.1	Estimation of safety margin against extreme weather conditions	95
4.2.2	Measures to increase robustness of the plant against extreme weather conditions.	96
5	Loss of electrical power and loss of ultimate heat sink	99
5.1	Nuclear reactors	99
5.1.1	Loss of electrical power	99
5.1.1.1	Loss off-site power	99
5.1.1.1.1	Design provisions	99
5.1.1.1.2	Autonomy of the on-site power sources	101
5.1.1.2	Loss off-site power and loss of the ordinary back-up AC power source	101
5.1.1.2.1	Design provisions	101

5.1.1.2.2	Battery capacity, duration and possibilities to recharge batteries	102
5.1.1.3	Loss off-site power, back-up AC power sources and permanently installed diverse back-up AC power sources	102
5.1.1.3.1	Battery capacity, duration and possibilities to recharge batteries	102
5.1.1.3.2	Actions foreseen to arrange exceptional AC power supply from transportable or dedicated off-site source	102
5.1.1.3.3	Competence and time needed to make necessary electrical connections	102
5.1.1.3.4	Time available to provide AC power and to restore core cooling before fuel damage	102
5.1.1.4	Conclusions on the adequacy of protection against loss of electrical power	102
5.1.1.5	Measures to increase robustness of the plant in case of loss of electrical power	102
5.1.2	Loss of the ultimate heat sink	103
5.1.2.1	Plant cooling conditions	104
5.1.2.2	The ultimate heat sink and alternate ultimate heat sink	104
5.1.2.3	Design provisions to prevent the loss of the primary ultimate heat sink	105
5.1.2.4	Loss of the primary ultimate heat sink	106
5.1.2.4.1	Availability of an alternate heat sink	106
5.1.2.4.2	Possible time constraints for availability of alternate heat sink and possibilities to increase the available time	106
5.1.2.5	Loss of the primary ultimate heat sink and the alternate heat sink	106
5.1.2.5.1	External actions foreseen to prevent fuel degradation	106
5.1.2.5.2	Time available to restore core cooling before fuel damage	107
5.1.2.6	Conclusions of the adequacy of protection against loss of ultimate heat sink	107
5.1.2.7	Measures to increase robustness of the plant in case of loss of ultimate heat sink	107
5.1.3	Loss of the primary ultimate heat sink, combined with station black out	108
5.1.3.1	Time of autonomy of the site before loss of normal reactor core cooling conditions	108
5.1.3.2	External actions foreseen to prevent fuel degradation	108
5.1.3.3	Measures to increase robustness of the plant in case of loss of primary ultimate heat sink, combined with station black out	108
5.2	Spent fuel storage pools	109
5.2.1	Loss of electrical power	109
5.2.1.1	Measures to increase robustness of the plant in case of loss of loss of electrical power	109
5.2.2	Loss of the ultimate heat sink	109
5.2.2.1	Measures to increase robustness of the plant in case of loss of ultimate heat sink	109
5.2.3	Loss of the primary ultimate heat sink, combined with station black out	109
5.2.3.1	Measures to increase robustness of the plant in case of loss of primary ultimate heat sink, combined with station black out	109
5.3	Supplementary consequences	110

6	Severe accidents management	111
6.1	Organization and arrangement of the licensee to manage accidents	111
6.1.1	Organization of the licensee to manage the accident	111
6.1.1.1	Staffing and shift management in normal operation	113
6.1.1.2	Plans for strengthening the site organization for accident management	113
6.1.1.3	Measures taken to enable optimum intervention by personnel	113
6.1.1.4	Use of off-site technical support for accident management	114
6.1.1.5	Procedures, training and exercises	116
6.1.2	Possibility to use existing equipment	117
6.1.2.1	Provisions to use mobile devices	117
6.1.2.2	Provisions for and management of supplies	117
6.1.2.3	Management of radioactive releases, provisions to limit them	118
6.1.2.4	Communication and information systems	119
6.1.3	Evaluation of factors that may impede accident management and respective contingencies	120
6.1.3.1	Extensive destruction of infrastructure or flooding around the installation that hinders access to the site	120
6.1.3.2	Loss of communications facilities / systems	120
6.1.3.3	Impairment of work performance due to high local dose rates, radioactive contamination and destruction of some facilities on site	120
6.1.3.4	Impact on the accessibility and habitability of the main and secondary control rooms, measures to be taken to avoid or manage this situation	121
6.1.3.5	Impact of the different premises used by the crisis teams or for which access would be necessary for management of the accident	122
6.1.3.6	Feasibility and effectiveness of accident management measures under the conditions of external hazards (earthquakes, floods)	122
6.1.3.7	Unavailability of power supply	122
6.1.3.8	Potential failure of instrumentation	123
6.1.3.9	Potential effects from the other neighbouring installations at site	123
6.1.4	Conclusion of the adequacy of organizational issues for accident management	123
6.1.5	Measures to enhance accident management capabilities	123
6.2	Accident management measures in place at the loss of core cooling function	124
6.2.1	Before occurrence of fuel damage	124
6.2.2	After occurrence of fuel damage	125
6.2.3	Measures to increase the accident management in case of loss of core cooling function	125
6.3	Maintaining containment integrity after fuel damage in the reactor core	125
6.3.1	Elimination of fuel damage / meltdown in high pressure	125
6.3.2	Management of hydrogen risks inside the containment	126
6.3.3	Prevention of overpressure of the containment	126
6.3.3.1	Design provisions	126
6.3.3.2	Operational and organizational provisions	126

6.3.4	Prevention of re-critically	126
6.3.4.1	Design provisions	126
6.3.4.2	Operational provisions	127
6.3.5	Prevention of base mat melt through	127
6.3.6	Need for and supply of electrical AC and DC power and compressed air to equipment used for protecting containment integrity	127
6.3.7	Measuring and control instrumentation needed for protecting containment integrity	127
6.3.8	Conclusion on the adequacy of severe accident management systems for protection of containment integrity	128
6.3.9	Measures to enhance capability to maintain containment integrity after occurrence of severe fuel damage	128
6.4	Accident management measures to restrict radioactive releases	128
6.4.1	Radioactive releases after loss of containment integrity	128
6.4.2	Accident management after uncovering of the top of fuel in the fuel pool	129
6.4.2.1	Hydrogen management	129
6.4.2.2	Providing adequate shielding against radiation	129
6.4.2.3	Restricting releases after severe damage of spent fuel in the fuel storage pools	129
6.4.2.4	Instrumentation needed to monitor the spent fuel state and to manage the accident	129
6.4.2.5	Availability and habitability of the control room	129
6.4.3	Conclusion of the adequacy of measures to restrict the radioactive releases	129
6.4.4	Measures to enhance capability to restrict radioactive releases	130
7	Other extreme hazards	131
7.1	Internal explosion	131
7.1.1	General description of the event	131
7.1.2	Potential consequences for the safety systems	132
7.2	External explosion	133
7.2.1	General description of the event	133
7.2.2	Potential consequences for the safety systems	134
7.3	Internal fire	135
7.3.1	General description of the event	135
7.3.2	Potential consequences for the safety systems	136
7.4	External fire	136
7.4.1	General description of the event	136
7.4.2	Potential consequences for the safety systems	136
7.5	Airplane crash	137
7.5.1	General description of the event	137
7.5.2	Potential consequences for the safety systems	137
7.6	Toxic gases	138
7.6.1	General description of the event	138
7.6.2	Potential consequences for the safety systems	138
7.7	Large grid disturbance	138
7.7.1	General description of the event	138
7.7.2	Potential consequences for the safety systems	139
7.8	Failure of systems by introducing computer malware	139
7.8.1	General description of the event	139
7.8.2	Potential consequences for the safety systems	140

7.9	Internal flooding	141
7.9.1	General description of the event	141
7.9.2	Potential consequences for the safety systems	144
7.10	Blockage of cooling water inlet	145
7.10.1	General description of the event	145
7.10.2	Potential consequences for the safety systems	145
List of tables .		146
List of figures		146
Appendix A	Equipment of auxiliary systems	149
Appendix B	Electrical power system	155
Appendix C	Back-up power consumers	159
Appendix D	Assessment of heat removal capacity of the pool	161

Prologue

On March 11, 2011, a large part of the Japanese eastern coastal area was struck by an earthquake of enormous magnitude, followed by a devastating tsunami. This natural disaster killed thousands of people and caused extensive damage to Japanese cities and infrastructure. After the earthquake, the nuclear reactors from the Japanese Nuclear Power Plant station Fukushima Dai-ichi shut down automatically. However the station failed to adequately maintain all of its safety functions after been hit by the tsunami initiated by the earthquake. As a result the local environment suffered from radioactive releases, requiring large zones to be evacuated, and generating serious concerns internationally about nuclear safety.

In the wake of the disaster the European Union decided to assess safety of all operating nuclear power reactors in its member states. This safety assessment focusses on extreme natural hazards, beyond the standard safety evaluations which regularly have to be performed to demonstrate the safety of a nuclear power plant and addresses the safety margins of nuclear power plants in the light of the events which occurred at Fukushima: extreme natural events challenging the plant safety functions and leading to a severe accident.

The Dutch Regulatory Body asked the Reactor Institute Delft (RID) to perform a safety assessment for the Hoger Onderwijs Reactor (HOR).

Consequences of these extreme hazards for the HOR at the RID premises have been evaluated using available safety analyses, supplemented by engineering judgement. In this way, the robustness of the research reactor was assessed and the safety margins were identified. The present report documents the results of this Complementary Safety margin Assessment (CSA).

Executive Summary

Complementary Safety margin Assessment (CSA)

As a consequence of the accident at the Fukushima Dai-ichi Nuclear Power Plant (NPP) in Japan, the European Council meeting on March 24th and 25th 2011 declared that 'the safety of all EU nuclear plants should be reviewed, on the basis of a comprehensive and transparent risk assessment ('stress tests'). Based on this decision, the Dutch Ministry of Economic affairs, Agriculture and Innovation (EL&I) requested RID, the operator of the Hoger Onderwijs Reactor (HOR) to perform a stress test of this facility based on the ENSREG specifications. In addition, the Ministry indicated that 'deliberate disturbances' should be taken into account as well. This request was implemented by RID as the Complementary Safety margin Assessment (CSA) of the Hoger Onderwijs Reactor (HOR) of which the results are documented in this report.

Methodology

The methodology of the assessment consists of evaluating the HOR's response when facing a set of extreme situations and verifying the preventive and mitigative measures necessary to ensure the safety of the reactor. In this assessment, the possibility of cliff-edge effects beyond the level of protection is identified.

The assessment approach is essentially deterministic: when analysing an extreme scenario, sequential loss of protective systems and measures is assumed, regardless its credibility.

The assessment considers three elements:

- Provisions incorporated in the design basis and the facility's conformance to its design requirements;
- Evaluation of the design basis;
- Assessment of the margins "beyond design"; how far can the design envelope be stretched until accident management provisions (design and operational) can no longer prevent fuel damage and/or a radioactive release to the environment.

The assessment of the margins "beyond design" might require information about the plant that is not always available. In those cases engineering judgement has been used to conservatively determine the margins.

The assessment leads to insights into severe accident conditions and how the HOR responds, even if measures provided for that situation would fail. The intention is that an increasing threat (for example, an increasingly higher flood level) is assumed, so as to determine how the HOR responds and to what level of threat the safety systems work adequately. Following a deterministic approach for assessing the safety margins for the different issues, it is

important to know the likelihood of such an event as basis for possible further evaluation and improved measures. This information is also presented in this report.

The following issues are dealt with:

- Earthquake;
- Flooding;
- Extreme weather conditions;
- Loss of electrical power and loss of ultimate heat sink;
- Severe accident management;
- Other extreme events.

CSA in relation to continuous improvement at the HOR

Within RID safety, including nuclear safety, has overriding priority both in organisation and operations. This is implemented through a pro-active approach to prevent and control possible hazards with respect to safety of individuals and the environment and a pursuit of continuous improvement.

Part of this is the execution of an extensive safety evaluation, scheduled every 10-years, concerning nuclear safety and radiation protection. The objective of this evaluation is to compare the existing situation to the state-of-the-art requirements and best practices using a comprehensive assessment as to whether the design basis and the safety documentation are still valid, arrangements in place to assure the plant's safety are still correct and effective, and the reactor complies with current national and international standards and practices.

RID recently completed this safety evaluation for the period 2000-2010 that resulted in a series of recommendations to improve the design, operation and organisation of the HOR and RID respectively.

The underlying CSA expands this assessment and reviews the robustness of the HOR.

Main conclusions of the assessment

The main conclusion on the robustness of the Hoger Onderwijs Reactor against the assessed extreme events can be summarized as follows.

Basically the HOR is safe and sound designed and operated; it is very robust and hardly impacted by the hazards under consideration, unless extreme limits are exceeded. This is due to its design that makes the HOR almost independent from internal and external support (systems) to assure the basic safety functions of reactivity control, cooling and confinement.

In this respect, maintaining these functions is:

- Independent from electrical power supply, both by the external grid and/or by the diesel generator;
- Assured as long as pool water is available for processing of the decay heat, by heating-up and evaporation. It takes years before uncovering of the core occurs;
- Performed by "fail-safe" isolation valves of the pool and of the containment.

Therefore no additional measures are included in the design to deal with extending extreme events.

Nevertheless, improvements in this respect may be found in dealing with issues that are related to the loss of pool water as a single event or in combination with loss of confinement.

The alternative cooling by air is not unambiguously demonstrated. Preparedness by means and procedures to mitigate consequences of such extreme events should be reconsidered. In some cases robustness can be increased by implementation or enhancement of procedures or instructions. In addition, despite the robustness of the HOR, recommendations have been made to extend the monitoring capabilities. This to assure that at any circumstances information is available that confirms that the HOR is in a safe state.

The recommendations to improve the robustness of the HOR are summarised below. Distinction is made between measures, studies and procedures or instructions.

Summary of recommendations

Implementation of these measures will most probably require hardware modifications	Origin
M1 The magnetic holding force of the control rods should be tested to ascertain the assumption that drop of these rods into the core will occur in case of the type of earthquakes to be expected in the Delft region.	Ch 2.2.4
M2 For extreme rainfall the roof of the control room is not sufficiently protected. It is recommended to provide the roof of the control room with blocking proof rainwater drains, like overflow holes, to prevent accumulation of rainwater and exceedance of the roof design load.	Ch 4.1.1.5
M3 If practically achievable, connect the containment ventilation system to the Diesel Generator in order to maintain filtering capabilities after loss of off-site power	Ch 6.3.9

In the framework of the CSA, the maximum resistance of the HOR against external events has been investigated, whereas traditionally the HOR design is investigated against certain pre-defined external events. These different approaches require different analysis and studies. Within the timeframe of the CSA, it was not possible to perform extensive studies and in some cases engineering judgment has been applied for establishing the margins. In general a conservative approach is chosen when applying engineering judgment. In some areas, additional studies could therefore reveal that the actual margins are larger than those margins presented in the CSA report. Furthermore, in some cases, additional studies could reveal measures for further increasing the margins.

Origin

S1	Evaluation of loss of coolant possibilities of the HOR If draining of the pool in case of pipe-break immediate underneath the connection to the pool appears to be an issue, measures should be investigated to isolate this kind of leakages.	Ch 5.1.2.7
S2	The cooling capabilities in case of loss of pool water should be investigated. Evaluation of the core / spent fuel integrity during cooling of the core partly covered by water or cooling of the core by air.	Ch 2.2.4 Ch 5.1.2.7, Ch 5.2.2.1
S3	A seismic evaluation of the HOR stack is recommended. (Connection with S4/S5 and vice versa)	Ch 2.2.4
S4	It is recommended to investigate the allowable wind load on the ventilation stack. (Connection with S3/S5 and vice versa)	Ch 4.2.2
S5	The possible impact of the ventilation stack on the reactor building should be investigated. (Connection with S3/S4 and vice versa)	Ch 2.2.4 Ch 4.2.2
S6	Revise and clarify the organizational chart in the RID Emergency Plan (e.g. replace IRI by RID).	CH 6.1.5
S7	Investigate/determine the fire resistance of the synthetic plate material at the inside of the containment; perform a fire analysis from the viewpoint of nuclear risks.	Ch 7.3.2
S8	Evaluation of the emergency plans which need to be activated in case of an APC with core damage and release of radioactive material. For this, a HOR specific APC accident analysis should be performed in order to make reliable estimations of the consequences.	Ch 7.5.2

S9	Investigate the needs for monitoring the condition of the HOR in LOOP or SBO situations, the availability of the diesel generator and UPS related to their (time-limited) capacity to supply power and assure monitoring; increase of the battery capacity might be possible	Ch 5.1.1.5
S10	Evaluate advantages of introducing a load reduction or load shedding programme in case diesel fuel saving is needed to extend operation time of the diesel generator when refuelling fails.	Ch 5.1.1.5
S11	Investigate if the water seal needs modification in such a way that flooding of the inlet will not result in higher "seal break pressure".	Ch 3.3.2
S12	Investigate possibilities to extend the monitoring capability in the alternate Alarm Staff Room (L&R building) by availability of measuring data and E-power.	Ch 5.1.1.5
S13	Evaluate the resistance against earthquake loading of the two support points of the staircase to the central turn pivot of the crane.	Ch 2.2.1.4

The CSA showed that the robustness of the HOR against external hazards can be increased further by implementation of a number of procedures.		Origin
P1	<p>Although means to supply water to the storage tank are available, an instruction is missing and should be drafted.</p> <p>Drafting a procedure for:</p> <ul style="list-style-type: none"> • Replenishment of pool water by supply of water stored in several tanks inside RID. • Implementation of supply of water to the storage tank by the fire fighting system. <p>Training and testing should be defined in this procedure as well.</p>	<p>Ch 2.2.4</p> <p>Ch 5.1.2.7</p> <p>Ch 6.2.3</p>
P2	Improve means for diesel fuel transfer from the main tank to the day tank and provide a procedure or instruction for refueling of both tanks during emergencies or long term loss of off-site power; assure diesel fuel supply.	<p>Ch 5.1.1.5</p> <p>Ch 6.1.5</p>
P3	Make an inventory of equipment of Fire Brigade Haaglanden and adjust plans for possible emergency provisions,	Ch 6.1.5
P4	<p>Both procedures in "Bedrijfsnoodprocedures" and the "Aanvalsplan" for containment pressure relief should be checked on consistency (1 kPa versus approaching 10 kPa) and effectiveness.</p> <p>Add the instruction that consultation of Radiation Protection Service (SBD) is needed about internal recirculation over the filters in order to reduce release fractions before pressure relief.</p>	Ch 6.1.5
P5	Check the preparedness of local emergency services (e.g. Ambulance personnel) for radiological events.	Ch 6.1.5

P6	For the relocation of the core to the other pool section in case of loss of pool water, the handling time and dependence on tools or equipment should be evaluated by performing a training exercise of the existing emergency instruction. The required time will determine the leak rate that can be handled. The identified tools, dependencies (e.g. E-power for polar crane for spent fuel relocation) and expected dose rates will make it clear in what situations relocation is an option.	Ch 5.1.2.7 Ch 6.2.3
P7	The instruction on core relocation in case of a leak in pool section 2 should be complemented by guidance on the handling of spent fuel (depending on their ability to cool in air, connection with S1/S2).	Ch 5.2.2.1 Ch 6.2.3
P8	The existing instruction for refilling the water seal should be checked for applicability in case of an unfortunate "break" of the seal as to restore the confinement function.	Ch 6.3.9
P9	An evaluation if the current emergency plans give sufficient guidance in the extreme event of uncovering of the fuel.	Ch 6.4.4

List of abbreviations

AC	Alternating Current
AIS	Automatisch Indrijven Staven (power reduction)
APC	Airplane Crash
AUHS	Alternate Ultimate Heat Sink
BDBA	Beyond Design Base Accident
BHV	Internal First Response/Aid
BIS	Bassin ISolatie (isolation of the pool)
BISNIS	Big Sample Neutron Irradiation System
COSYMA	Code System for Maria (the EC program Methods for Assessing the Radiological Impact of Accidents)
CRS	Central monitoring system
CSA	Complementary Safety margin Study
DC	Direct Current
DBA	Design Base Accident
DBE	Design Basis Earthquake
DBR	Dry Irradiation Room
EMS	European Macro-seismic Scale
ENSREG	European Nuclear Safety REgulatory Group
ERO	Emergency Response Centre
FMVG	Facilities Management and Real Estate
HEPA	High Efficiency Particulate Air (filter)
HOR	Hoger Onderwijs Reactor
IAEA	International Atomic Energy Agency
IPCC	Intergovernmental Panel on Climate Change
IRI	Interuniversitair reactor Instituut

KFD	Nuclear Inspectorate
KNMI	Royal Netherlands Meteorological Institute
LAHS	Loss of Alternate Heat Sink
LEU	Low Enriched Uranium
LOCA	Loss of Cooling Accident
LOOP	Loss Of Offsite Power
LUHS	Loss of Ultimate Heat Sink
MMI	Mercalli Intensity Scale
MTR	Materials Testing Reactor
NAP	Nieuw Amsterdams Peil
NPK	National Plan for Nuclear Emergency Planning and Response
NPP	Nuclear Power Plant
NVR	Nucleaire Veiligheids Richtlijnen (Nuclear Safety Rules and Guidelines)
OLC	Operating Limits and Conditions
RBV	Reactor BedrijfsVergrendeling (reactor operation locking)
RID	Reactor Instituut Delft
RIS	Reactorhal ISolatie (isolation of the reactor hall)
RIVM	Governmental Institute for Public Health and Environment
RK	Regelkamer (control room)
RPS	Reactor Protection System
RSA	Reactor Snel Afschakeling (scram)
RSV	Reactor Start Vergrendeling (start-up locking)
RWS	Rijkswaterstaat; department of the Ministry of Infrastructure and Environment
SAM	Severe Accident Management
SBD	Radiation Protection Department
SBO	Station Black Out

SSC	Systems, Structures and Components
TU Delft	Technische Universiteit Delft
UHS	Ultimate Heat Sink
UPS	Un-interrupted Power supply System
WENRA	Western European Nuclear Regulator Association

Introduction

Background and objective

As a consequence of the accident at the Fukushima Dai-ichi Nuclear Power Plant (NPP) in Japan, the European Council meeting on March 24th and 25th 2011 declared that "the safety of all EU nuclear plants should be reviewed, on the basis of a comprehensive and transparent risk assessment ('stress tests')".

On the basis of the proposals made by the Western European Nuclear Regulator Association (WENRA), the European Commission and members of the European Nuclear Safety Regulatory Group (ENSREG), it was decided to agree upon "an initial independent regulatory technical definition of a 'stress test' and how it should be applied to nuclear facilities across Europe". The "EU 'stress test' specifications" were finally provided by ENSREG.

These EU wide tests will be an addition to the safety standards already in place at national level. The aim of these tests is a targeted re-assessment of the safety margins of nuclear power plants in the light of the events which occurred at Fukushima: extreme natural events challenging the plant safety functions and leading to a severe accident.

RID has agreed with the regulator to voluntarily participate in the stress test as outlined in the ENSREG specifications(reflected by the table of contents).

In addition the regulator indicated that in the assessment 'deliberate disturbances' should be taken into account. This request was implemented by RID as the RID Complementary Safety margin Assessment (CSA) of which the results are presented in this report.

The objective of the CSA is to perform a reassessment of the design basis, the safety margins and cliff-edge effects of the HOR research reactor at the RID site and is mainly based on the guidance provided by ENSREG regarding the so-called 'stress-test'. This assessment consists on the one hand of an evaluation of the response of the HOR research reactor facing a set of extreme initiating events like earthquake and flooding, and on the other hand of a verification of the features the design encloses to ensure the safety of the HOR research reactor.

The CSA focuses on extreme natural events like earthquake and flooding. It will also assess the consequences of loss of safety functions due to indirect initiating events like a large disturbance from the electrical power grid impacting AC power distribution systems, external fire or airplane crash. Furthermore, an assessment of man-made and of other extreme natural events has been carried out.

Assessment methodology

The methodology of the assessment consists of evaluating the HOR's response when facing a set of extreme situations and verifying the preventive and mitigation measures necessary to ensure the safety of the reactor. In this assessment, the possibility of cliff-edge effects beyond the level of protection is identified.

The assessment approach is essentially deterministic: when analysing an extreme scenario, sequential loss of protective systems and measures is assumed.

The assessment considers three elements:

- Provisions incorporated in the design basis and the facility's conformance to its design requirements;
- Evaluation of the design basis;
- Assessment of the margins 'beyond design'; how far can the design envelope be stretched until accident management provisions (design and operational) can no longer prevent fuel damage and/or a radioactive release to the environment.

The assessment of the margins 'beyond design' might require information about the plant that is not always available. In those cases engineering judgement has been used to conservatively determine the margins.

The assessment leads to insights into severe accident conditions and how the HOR reacts, even if measures provided for that situation would fail. This means that for the determination of the safety margins, a deterministic approach is chosen. The intention is that an increasing threat (for example, an increasingly higher flood level) is assumed, so as to determine how the HOR system respond and to what level of threat the safety systems work adequately. Following a deterministic approach for assessing the safety margins for the different issues, it is important to know the likelihood of such an event as basis for possible further evaluation and improved measures. This information is also presented in this report.

The following issues are dealt with:

- Earthquake;
- Flooding;
- Extreme weather conditions;
- Loss of electrical power and loss of ultimate heat sink;
- Severe accident management;
- Other extreme events.

In chapter 2 up to and including 7 these issues are elaborated, preceded by chapter 1 that lists the general data of the reactor and the site.

1 General data of the site/plant

1.1 The Reactor Institute Delft

The Reactor Institute Delft (RID) is part of the Faculty of Applied Sciences of the Delft University of Technology. The RID operates one research reactor: the Hoger Onderwijs Reactor (HOR). According to the Dutch Nuclear act, the Executive Board of the university, being the licensee, is responsible for the HOR.

1.2 Brief description of the site characteristics

The RID is located at the premises of the Delft University of Technology, nearby the city of Delft (see Figure 1-1), in the western part of the "Zuidpolder van Delfgauw" area. Neighbouring towns, within a distance of approx. 5km. are Delft, Pijnacker and Schipluiden. The HOR encloses several buildings. A picture is shown in Figure 1-2.

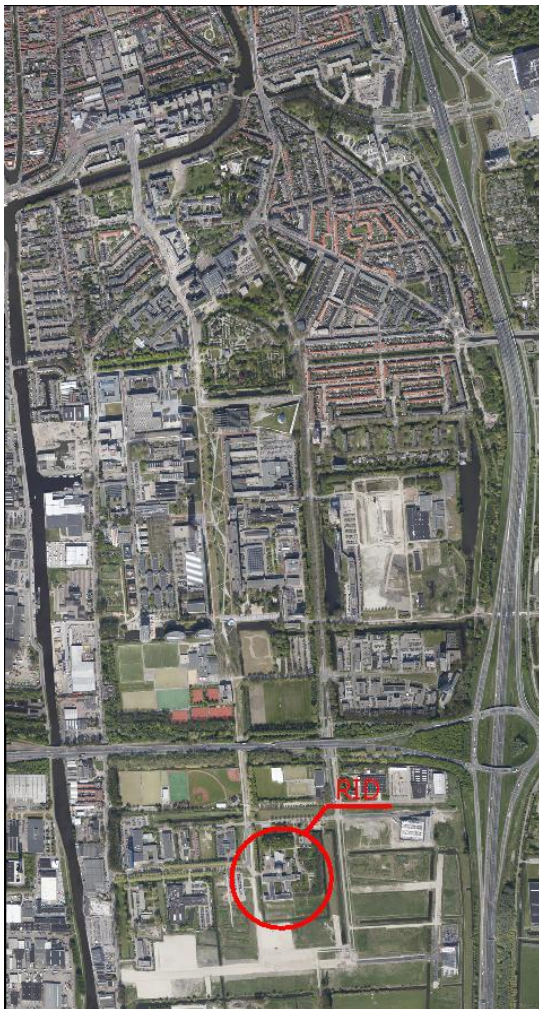

Figure 1-1 : Location of the RID site



Figure 1-2 : View of RID site

The shortest distance of the reactor to the boundary of the RID premises (public area), the Mekelweg, is 75m. An area with a diameter of 300m, surrounding the HOR, encloses a few buildings of the university. These buildings reside south of the Kruithuisweg which is situated at a distance of 400m to the HOR. A listing of these buildings and their related distances is presented in Table 1-1.

Table 1-1: Buildings in the neighbourhood of the HOR

Building	Distance
Employment houses	100 m
Division transport & Logistics (TU Delft)	200 m
The Fellowship (TU Delft)	300 m
Facility Management & vastgoed (TU Delft)	300 m

The centre of the city of Delft is situated approximately 2km from the RID, in north-west direction. West of the RID, at 800m, a canal, the Delftse Schie, is located, that connects Rotterdam and Den Haag. The railway between these two cities passes at 1.1km; a business park is situated between the Delftse Schie and the railway. West of the railway, at approximately 1.2km distance of the HOR, lies the residence area Tanthof.

The highway A13, from Rotterdam to Amsterdam, runs east of the RID, at 600m distance of the HOR. East of the A13 there is a business park at 700m. At 1000m north-east of the HOR there is a district of the town of Delfgauw.

South of the HOR an expansion of Technopolis, a business area enclosing several industries, is planned. At present Deltaris and Holland Metrology are at a distance of 600m. Furthermore on the south side there is the polder of Midden Delftland that houses several farms and the municipality of Kandelaar at 3.5km. The northern border of the town of Schiedam is at 4.5km distance south of the HOR.

Rotterdam - The Hague airport is situated at a distance of 6 km to the south, the North Sea at 15km to the west and the Nieuwe Waterweg, the open waterway from the port of Rotterdam to the North Sea at 12km to the south.

Ground level (MAAIVELD) and at the same time level of the reactor hall floor is -1.2m NAP, see Figure 1-3. The water level of the site is controlled by the electric pumping stations of the Delftse Schie; this level is the reference (water) level of the "Zuidpolder van Delfgauw", the RID area, it is at -2.8m NAP (Amsterdam zero level) so 1.6m below ground level.

The seismic and geologic characteristics of the soil of the RID site do not require extra provisions of the design. The area is considered to be non-seismic.

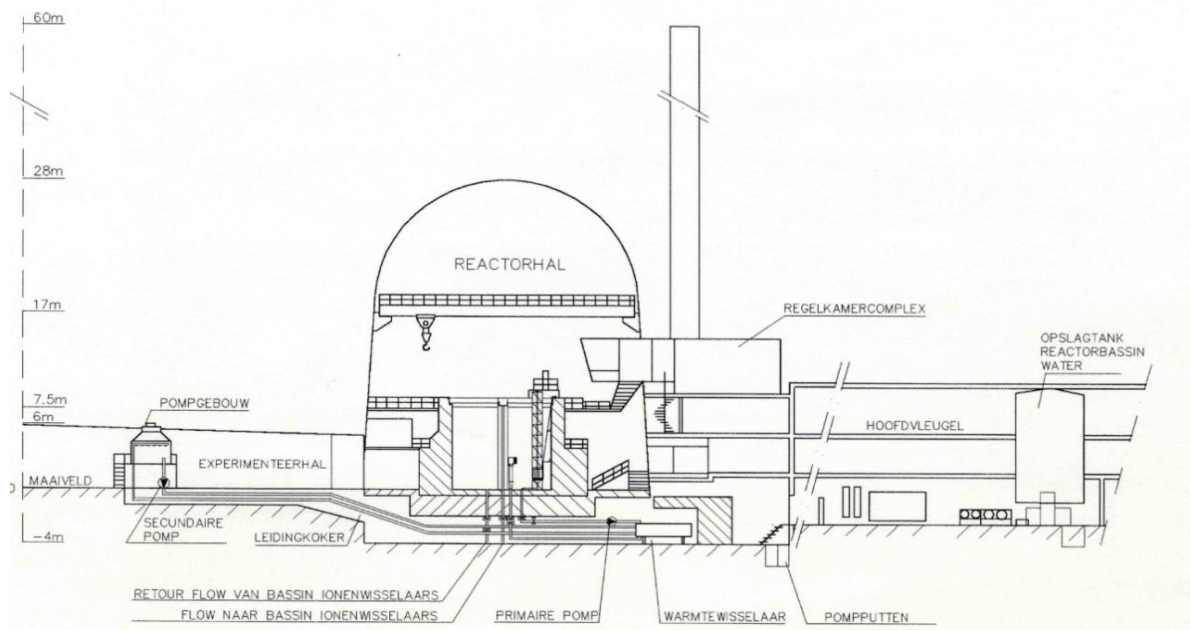

Figure 1-3 : levels at RID site, with ground or 'MAAIVELD' level at -1.2 m NAP.

1.3 Main characteristics of the unit

The HOR is facilitated by several buildings and constructions (see Figure 1-4).

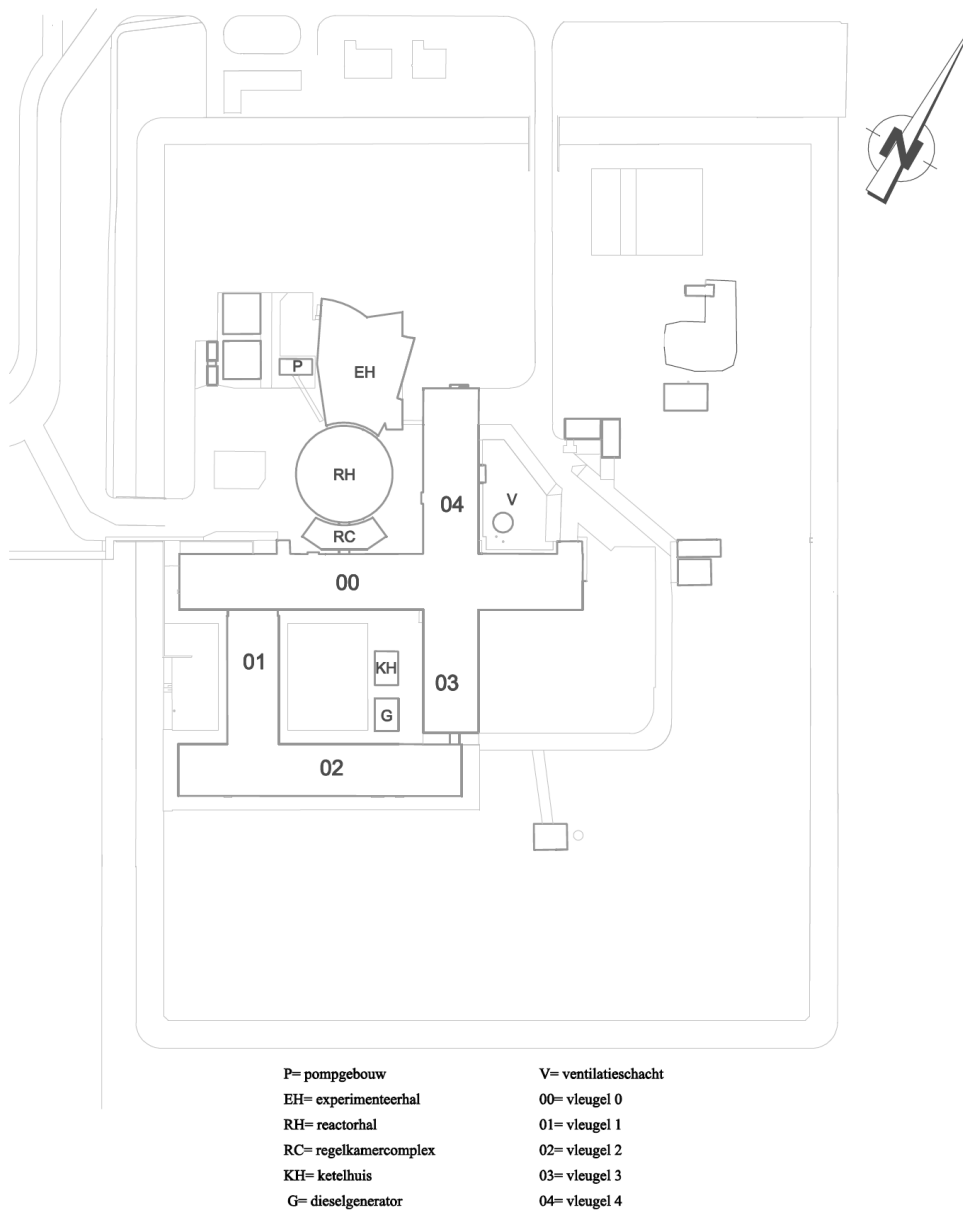

Figure 1-4: Site map of the RID

Successively the following facilities and systems will be described:

- Reactor;
- Core;
- Fuel storage;
- Reactor cooling system;
- Reactor hall;

- Control room and instrumentation;
- Ventilation;
- Water clean-up and make-up system;
- Electrical power system;
- Experimental facilities;
- Auxiliary systems.

The main characteristics of the HOR are listed in Table 2-1. This table includes a “control action” column that indicates scram (RSA) or power reduction (AIS) actions of the reactor protection system or the control system respectively in case indicated limits (column 2) are exceeded.

Table 1-2: Main characteristics of the HOR

Description	Value	Control action
General:		
type	pool	
maximum power level	3 MW	
nominal power level	2 MW	
moderator	water	
coolant	water	
Containment system	reactor hall	
volume reactor hall	20000 m ³	
minimum flow ventilation system	2.4 m ³ /s	AIS ¹
maximum under-pressure	1 kPa	Breakthrough of water seal
maximum over-pressure	10 kPa	Breakthrough of water seal
Pool:		
wall thickness	1 - 2.5 m	
depth	8300 mm	
cladding	stainless steel	
number of sections	2	
total volume	250 m ³	
volume section 1	75 m ³	
volume section 2	175 m ³	
minimum water level	8205 mm	RSA ² and BIS ³

¹ Automatisch Indrijven Staven (power reduction)

² Reactor Snel Afschakeling (scram)

³ Bassin ISolatie (pool isolation)

Description	Value	Control action
Cooling:		
until 750 kW power operation	natural	
up to 3MW power operation	forced	
minimum coolant flow	74.4 dm ³ /s	RSA
nominal T _{pool}	35 °C	
maximum T _{pool}	40 °C	AIS
nominal T _{primary} at heat exchanger (HE) inlet	35 °C	
maximum T _{primary} at HE inlet	52 °C	AIS
T difference HE primary-secondary side	9 °C	
Evaporation per week	3 m ³	
Core:		
number of standard elements	16	
number of control elements	4	
number of beryllium reflector elements	22	
Standard elements:		
type	MTR LEU	
enrichment	19.75 %	
fuel matrix	U ₃ Si ₂ -Al	
U ²³⁵ per element	300 g	
number of fuel plates per element	19	
dimensions per fuel plate	0.5x62x600 mm	
Control elements:		
type	MTR LEU	
enrichment	19.75 %	
fuel matrix	U ₃ Si ₂ -Al	
U ²³⁵ per element	158 g	
number of fuel plates per element	10	
dimensions per fuel plate	0.5x62x600 mm	
neutron absorber	B ₄ C	
control rod insertion/drop time	<0.65 s	

1.3.1 The reactor

The HOR is a light water reactor of the pool type. Although designed for 3MW, it is normally operated at a power of 2MW, due to the cooling capacity, or at 3MW for one hour per day.

The reactor is comprised of the pool (that can be separated into two sections by the pool door), the bridge, the hanger, the reactivity control system, the core, the chair and the suction head. The core is placed in the bottom part of the hanger. The hanger itself is at its top fixed by the bridge while the bottom part is kept in place by the chair and the suction head. Figure 1-5 is a side view of the reactor pool in which all the important components are shown.

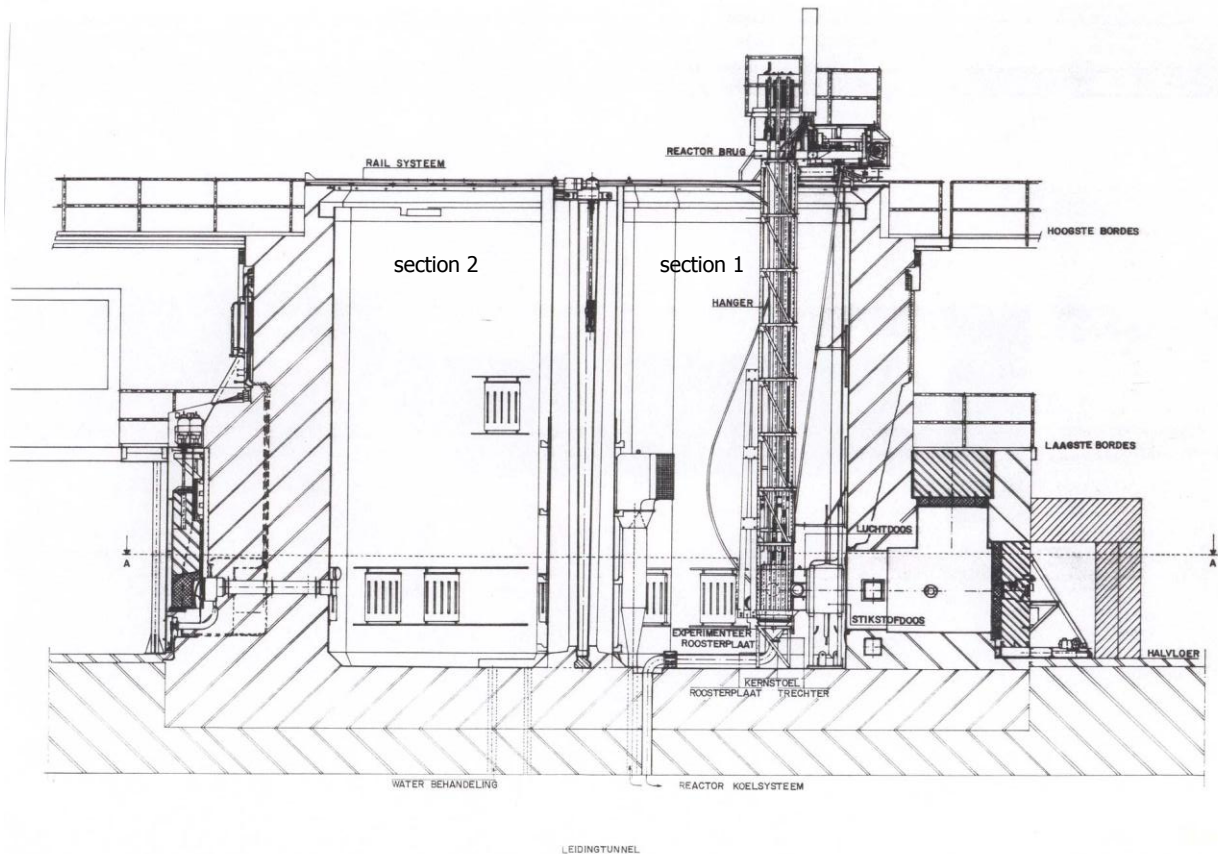

Figure 1-5: Side view of the reactor pool

The pool is constructed of reinforced concrete and forms a monolithic construction with the floor of the pool. The pool consists of a small (1) and large (2) section that can be separated by a pool door. Barite concrete is used for the small section as the core is usually positioned in this section⁴.

The pool is filled with demineralised water. The four functions of the pool water are: cooling, moderation, reflection and biological shielding. The water level is approximately 8.25 m.

To prevent leakage of the pool, a stainless steel lining at the inside of the pool was installed in 1971. The lining consists of plates of 1 m by 2 m. The thickness of the plates is 2 mm for the walls, 6 mm for the floor and 1 mm for the dry irradiation chamber (see "droge bestralingsruimte" fig 1.14). The plates are welded together. At the bottom of the pool

⁴ Technically, since the core is fixed to the bridge via the hanger, it is possible to operate the core in natural convection mode in other locations of the pool. However, usually the core is operated at 2MW with forced cooling in the position above the suction head of the primary system as shown in figure 1.5

several pipes pass the concrete floor of the pool into the basement below the reactor hall (in Dutch: de leidingtunnel).

1.3.2 The core

The reactor core includes a grid plate, an experimental grid plate, nuclear fuel elements, control rods and beryllium reflector elements. The grid plate is made of high purity aluminium with a thickness of 127 mm. 42 holes in a 6 by 7 pattern are fitted into the grid plate onto which the nuclear fuel and beryllium reflector elements are positioned. For the HOR reactor core nuclear fuel elements of the MTR type are used.

From January 2005 on, only Low Enriched Uranium (LEU) is used which contains Uranium Silicide (U_3Si_2) with a Uranium enrichment of less than 20 %. Two types of elements are utilized: standard and control elements. The standard elements are 76 mm by 80 mm and 875 mm long and contain 19 nuclear fuel plates. The control elements are 76 mm by 80 mm and 950 mm long and contain 10 nuclear fuel plates to enable the insertion of a control rod. A typical (standard) HOR LEU core contains 16 standard elements (E-xx) and 4 control elements EC-xx), see figure 1.6. In addition, this core includes 22 Beryllium reflector elements (R-xx). Two of these reflector elements provide the irradiation facilities (Bigbebe and Smallbebe)



A1	B1	C1	D1	E1	F1
	R-19	R-24	R-29	R-17	R-18
A2	B2	C2	D2	E2	F2
R-20		E-13 52.4	E-20 30.1	E-17 41.0	R-16
A3	B3	C3	D3	E3	F3
R-15	E-19 36.8	EC-03 49.6	E-27 4.5	EC-06 9.2	E-22 23.5
A4	B4	C4	D4	E4	F4
R-13	E-24 17.1	E-25 13.9		E-26 8.3	E-23 21.5
A5	B5	C5	D5	E5	F5
R-14	E-15 44.0	EC-04 42.9	E-28 0.0	EC-05 21.1	E-21 28.4
A6	B6	C6	D6	E6	F6
R-25	R-28	E-14 46.7	E-18 38.0	E-16 43.7	R-26
A7	B7	C7	D7	E7	F7
R-12	R-22	R-21	R-27	R-30	R-23

Figure 1-6: Standard HOR-LEU core

The four control rods are part of the reactivity control system. The control rods are made of a flat tubular aluminum casing which is filled with granular boron carbide (B_4C), a neutron absorbing material. The helium gas that is produced when neutrons are captured by boron carbide is then stored in aluminum wool. On the top side the control rod is provided with a shock damper. The shock damper is connected to an aluminum draw bar of approximately

7m long. Halfway the draw bar is provided with a water breaking system to reduce the falling rate of the control rod. On the top side the control rods are coupled to an electromagnet. By switching off the current, the control rods fall down by gravitational force within one second.

At normal operational conditions the control rods move up and down at an average speed of approximately 5.5 cm/min over a distance of 66 cm by means of an independent driving mechanism.

It is indicated that reactivity addition or reduction by experiments that will be placed in or nearby the core is taken into account at core design and efficiency check of the reactivity control system.

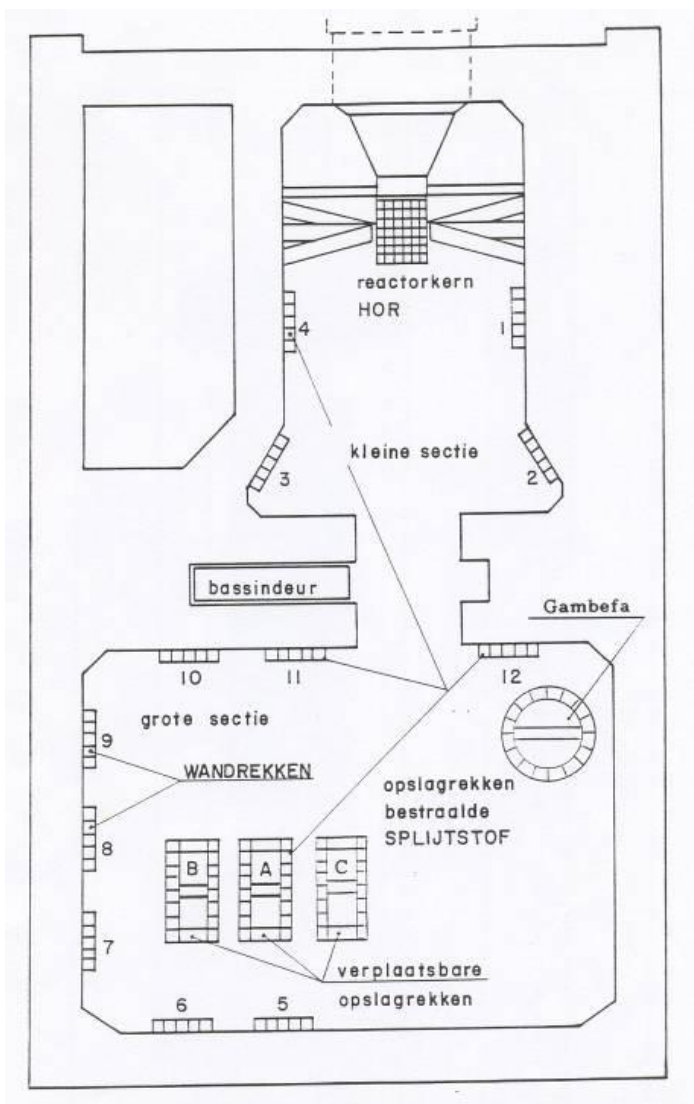

Figure 1-7: Spent fuel positions: in the pool

1.3.3 Fuel storage

Fresh fuel elements are stored in the appropriate dry storage vault. Spent fuel can only be stored in the storage racks in the pool. The maximum number of the spent fuel elements that can be stored is 78, in accordance with the OLC.

It has been determined that $k_{\text{effective}}$ of both storage facilities will not exceed 0.95. Even when the dry storage is submerged by clear (non-borated) water, $k_{\text{effective}}$ will not exceed this value. Figure 1-7 shows the positions of the storage racks in the pool.

The dry storage vault also includes one container in which fuel pins of the Delphi assembly are stored. It is shown that the $k_{\text{effective}}$ of this container is less than 0.78; also when it is submerged.

1.3.4 The reactor cooling system

The heat that is produced during reactor operation can be removed in two ways:

- By natural convection up to a maximum power of 750 kW;
- By forced circulation cooling up to a maximum power of 3 MW.

At normal operational conditions, usually at 2 MW, forced circulation cooling is used.

During natural convection the flow of the pool water is upwards through the core (buoyancy driven) due to density changes caused by an increasing temperature. During forced circulation cooling, the flow is downwards due to the suction power of the primary pump, which is located in the piping basement below the reactor hall (Figure 1-3).

The primary and secondary cooling systems are open systems. The primary system includes the pool, the core, the pool valves, the primary pump, the heat exchanger, the controlling valves and the diffuser (figure 1.8). The diffuser provides a calm and downwards flow of the primary water that is flowing back into the pool. Because the primary water passes through the core it contains radioactive elements. However due to the downwards flow of the primary water during forced circulation cooling, the short half-life of the radio nuclides and the circulation time, the radiation level at the water surface remains low. The primary water is continuously purified by ion exchange filtering (water recycling system). This clean-up system takes suction at top of the pool and returns purified water to pool section 2. In case the pool sections are separated by the pool door, return flow to section 1 is established by connecting the return line of the clean-up system to the primary cooling system injection pool line.

The secondary cooling system does not contain any radioactive elements and includes the heat exchanger, the secondary pump, (control) valves and evaporation cooling towers (Figure 1-8). The heat exchanger is located in the piping basement below the reactor hall. The secondary pump, the (control) valves and the cooling towers are located in the pump

building ("pompgebouw" (Figure 1-3)). Secondary cooling water is continuously drained and softened water is added to the secondary cooling system.

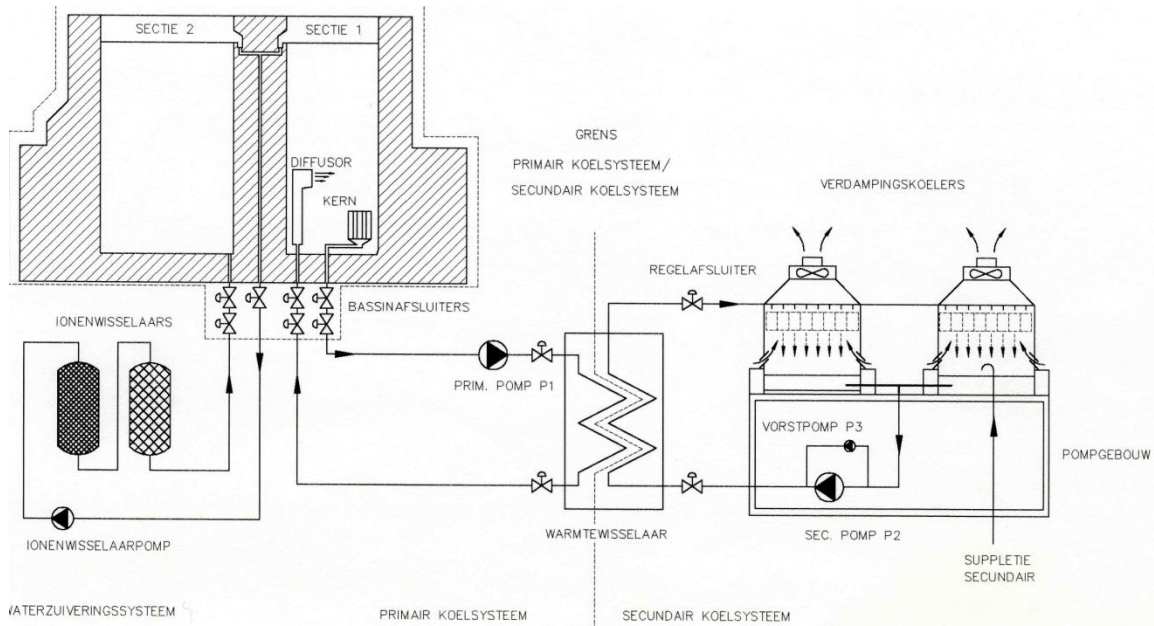

Figure 1-8: the heat removal system

1.3.5 The reactor hall

The reactor hall is the facility housing the HOR. It is shaped as a truncated cone with the segment of a sphere located on top. The dome is constructed of steel plates. For thermal isolation a layer of rock wool is placed on the outside, which in turn is covered by aluminium plates. On the interior acoustic isolation is fitted. The floor construction is made of reinforced concrete with a steel top layer to prevent leakage. At the base, the reactor hall has a diameter of 25m. At the transition from cone to sphere the diameter is 23m. The highest point is 28m above the floor level (Figure 1-2 and Figure 1-3).

The reactor hall has three entrances. There is one door for trucks; opening of this door is only allowed during reactor shut down (RSA protected). And there are two air locks for personnel entrance; one is situated on the ground floor and one at 10.5m above the floor level.

At 17m above floor level a polar crane is installed. Both tail ends are on wheels and placed on a rail track that is part of the wall of the reactor hall. The crane is equipped with two electrical hoists: one with a maximum load up to 15 tonnes force and one with a maximum load of 1.6 tonnes force. Both hoists have remote control.

1.3.6 Control room and instrumentation

The original control room, which is replaced by a new one, is still attached to the reactor hall wall on the inside at an elevated level of 10.5 m, facing in west direction. The present control room is located outside the reactor hall at the same elevation. The control room houses the instrumentation for safe operation and control of the reactor. Figure 1-9 shows a.o. the lay-out of the control room.

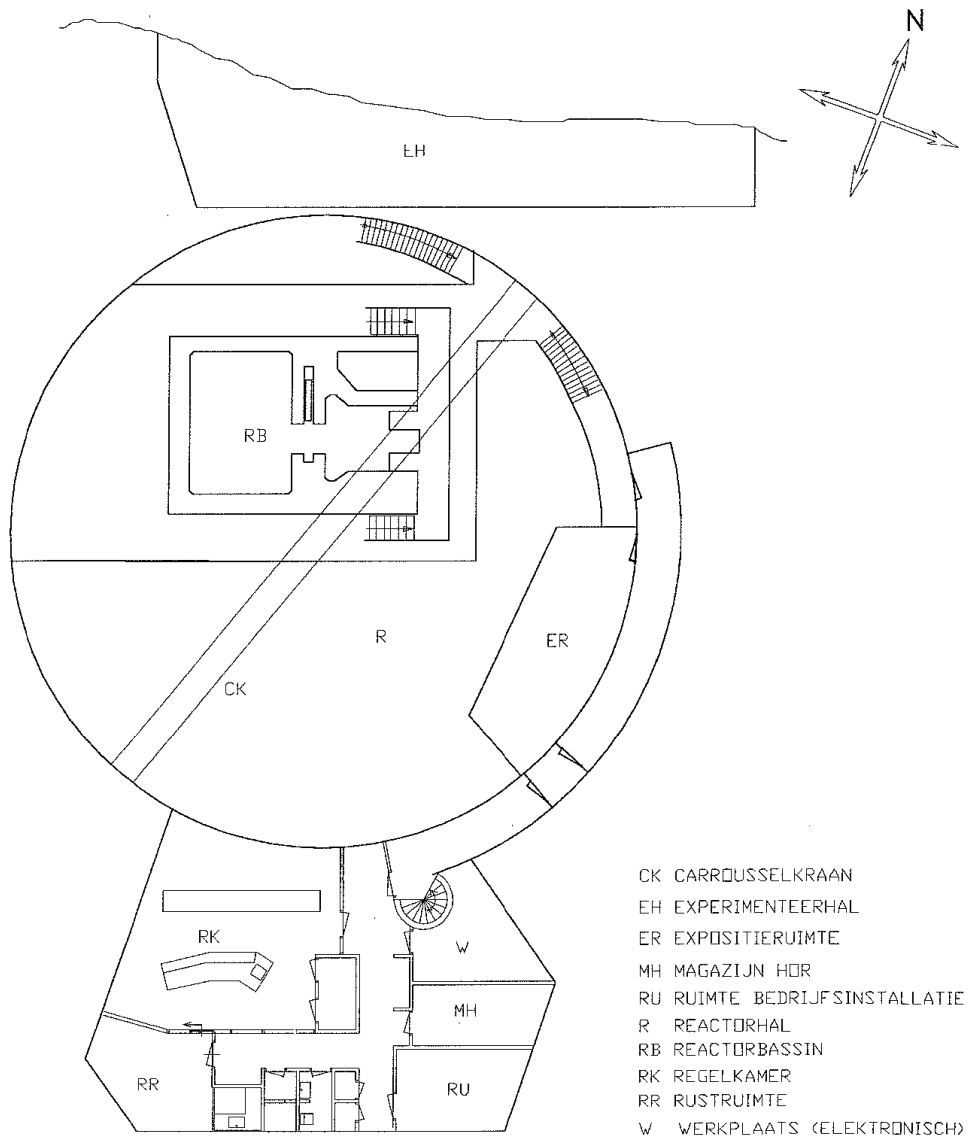

Figure 1-9: lay-out of reactor hall including the control room building ('regelkamer', RK)

The HOR instrumentation fulfils the following functions:

- Protecting the reactor process through the reactor protection system;
- Controlling the reactor process through the reactor control & operating system;
- Reporting data and deviations in the operational status through the reporting and alarm system.

The *reactor protection system* prevents the reactor attaining an unsafe condition by initiating the following actions:

- Reactor Scram (in Dutch: Reactor Snel Afschakeling, RSA): all the control rods fall down simultaneously and the reactor is stopped immediately;
- Pool Isolation (in Dutch: Bassin Isolatie, BIS): all the isolation valves of the primary cooling system and the water clean-up and make-up system close;
- Isolation of the Reactor Hall (in Dutch: Reactorhal Isolatie, RIS): all the gastight isolation valves of the reactor containment system, see 1.1.7, close.

Scram and/or isolation actions are initiated when safety limits are exceeded. Redundant (identical instrumentation) or diverse (different means) systems assure reliable operation of the protection system using a (1 out of 2, 3 or 4) or (2 out of 4) configuration. Figure 1-10 presents the combination of signals that trigger those actions.

The *reactor control & operating system* controls the nuclear fission process, the reactor cooling system and the auxiliary systems. Three limiting actions prevent interfering of the reactor protection system:

- Automatic running down of the control rods (in Dutch: Automatisch Indrijven Staven, AIS): all control rods are slowly moved down to reduce power until the triggering event (pre limit for RSA signal) is restored;
- Reactor operation locking system (in Dutch: Reactor Bedrijfs Vergrendeling, RBV): the reactor is not in an unsafe condition but normal operating conditions are not met which results in a scram;
- Reactor start interlocking system (in Dutch: Reactor Start Vergrendeling, RSV) prevents start of the reactor when certain start-up conditions are not met.

Initiation of these actions results from singular signals, e.g. AIS will be initiated on:

- $T_{\text{primary}} \geq 52 \text{ }^{\circ}\text{C}$ at inlet of the heat exchanger, OR
- $T_{\text{pool section1}} \geq 40 \text{ }^{\circ}\text{C}$.

The *reporting and alarm system* reports when deviations in the operational status occur and when necessary an alarm signal is generated. Deviations are announced through lights on the operation panel and are also registered on the process computer.

DOOR REACTORBEVEILIGINGS- EN BESTURINGSSYSTEEM TE BEHEEREN BEDRIJFSSTORING/ TE INDICEREN TOESTAND		INSTRUMENTATIEVARIABLE	GRENSWAARDE CRITERIUM	BESLISSINGS LOGICA	ONVOELDOENDE KOELING GEFORCEERD		ONVOELDOENDE KOELING(NAT)		OVERSCHRIJDING MAX. P		ONGEWENSTE REACTIVITEITS TOEVOEGING		FALENDE SIGNALERING KOELTRECHTER		VERLIES VAN DEBIET PRIMAIR		VERLIES VAN BASSINWATER		FALEN SPLIJTSTOF BEKLEDING DOOR ONVOELDOENDE WARMTEAFVOER (NATUURLIJK CONVECTIE)		FALEN SPLIJTSTOF BEKLEDING DOOR ONVOELDOENDE WARMTEAFVOER (GEFORCEERDE KOELING)											
					1	2	1	2	1	2	1	2	1	2	1	2	1	2	1	2	1	2	1	2	1	2						
PROCESVARIABLEN DIE EEN BEDRIJFSSTORING/AFWIJKING KUNNEN INDICEREN RESP. ER OP INGRIJPEN		VEILIGH.KAN. N-FLUX-NIVEAU	$\Phi \geq \Phi_{MAX}$	2 UIT 4																												
		VEILIGH.KAN. N-FLUX-TOENAMETEMPO	$\Phi / \geq MAX$	2 UIT 4									X																			
		VEILIGH.KAN. N-FLUX-AFNAMETEMPO	$-d\Phi/dt \geq MAX$	2 UIT 4																												
		KOELWATERACTIVITEIT	$\dot{D}_y \geq MAX$	1 UIT 1																												
		DOSISTEMPO BASSIN	$\dot{D}_y \geq MAX$	1 UIT 1																												
		DOSISTEMPO BRUG	$\dot{D}_y \geq MAX$	1 UIT 1																												
		AFGASACTIVITEIT	$\dot{b}/\beta \geq MAX$	1 UIT 1																												
		WATERHOOGTE BASSIN	$h \leq MIN$	1 UIT 4																												
		PRIMAIR DEBIET	$Q \leq MIN$	1 UIT 1																												
		Drukverschil secundair/primair warmtewisselaar	$\Delta p \geq MAX$	1 UIT 1																												
		TRECHTERPOSITIE	NIET GEKOPPELD	1 UIT 2																												
		TRECHTERPOSITIE	NIET ONTKOPPELD	1 UIT 2																												
			DEFEKT	1 UIT 2																												
FUNCTIE: BEVEILIGING TABEL 4-8					ACTIE		1	2	1	2	1	2	1	2	1	2	1	2	1	2	1	2	1	2								
							1	2	1	2	1	2	1	2	1	2	1	2	1	2	1	2	1	2	1	2	1	2	1	2		
							1	2	1	2	1	2	1	2	1	2	1	2	1	2	1	2	1	2	1	2	1	2	1	2	1	2
							1	2	1	2	1	2	1	2	1	2	1	2	1	2	1	2	1	2	1	2	1	2	1	2	1	2
							1	2	1	2	1	2	1	2	1	2	1	2	1	2	1	2	1	2	1	2	1	2	1	2	1	2
							1	2	1	2	1	2	1	2	1	2	1	2	1	2	1	2	1	2	1	2	1	2	1	2	1	2
							1	2	1	2	1	2	1	2	1	2	1	2	1	2	1	2	1	2	1	2	1	2	1	2	1	2
							1	2	1	2	1	2	1	2	1	2	1	2	1	2	1	2	1	2	1	2	1	2	1	2	1	2
							1	2	1	2	1	2	1	2	1	2	1	2	1	2	1	2	1	2	1	2	1	2	1	2	1	2
							1	2	1	2	1	2	1	2	1	2	1	2	1	2	1	2	1	2	1	2	1	2	1	2	1	2
							1	2	1	2	1	2	1	2	1	2	1	2	1	2	1	2	1	2	1	2	1	2	1	2	1	2
							1	2	1	2	1	2	1	2	1	2	1	2	1	2	1	2	1	2	1	2	1	2	1	2	1	2
							1	2	1	2	1	2	1	2	1	2	1	2	1	2	1	2	1	2	1	2	1	2	1	2	1	2

Figure 1-10: signals of the reactor protection system

1.3.7 The ventilation system

The ventilation system and the reactor hall form the reactor containment (see figure 1.11).

The functions of the ventilation system are:

- To refresh the air of the reactor hall;
- Creating and maintaining the under pressure of the reactor hall
To protect the reactor hall against exceeding the limits of under-(1kPa) and overpressure (10kPa) a water seal is installed between the inlet duct of the ventilation system and the reactor hall;
- Controlled disposal of the airborne radioactivity
Filtering of the incoming and outgoing air:
 - Inlet flow is filtered by a dust filter to prevent pollution of the reactor hall by intake of dust;
 - Outlet air is filtered by high efficiency (HEPA; efficiency of 99.95% for particles larger than 0.3 μ m) filters to prevent release of radioactive material that is produced and/or released from the reactor into the reactor hall.
- Heating of the incoming air;
- Containment isolation/recirculation.

In case the concentration of radioactive materials in the ventilation outlet flow exceeds prescribed limits, the containment isolation valves will be closed. Internal recirculation of air can be started manually (in non-LOOP conditions).

Due to safety aspects the active components of the ventilation system, such as ventilators and isolation valves are redundant. The ventilation system is independent of the reactor isolation system (RIS).

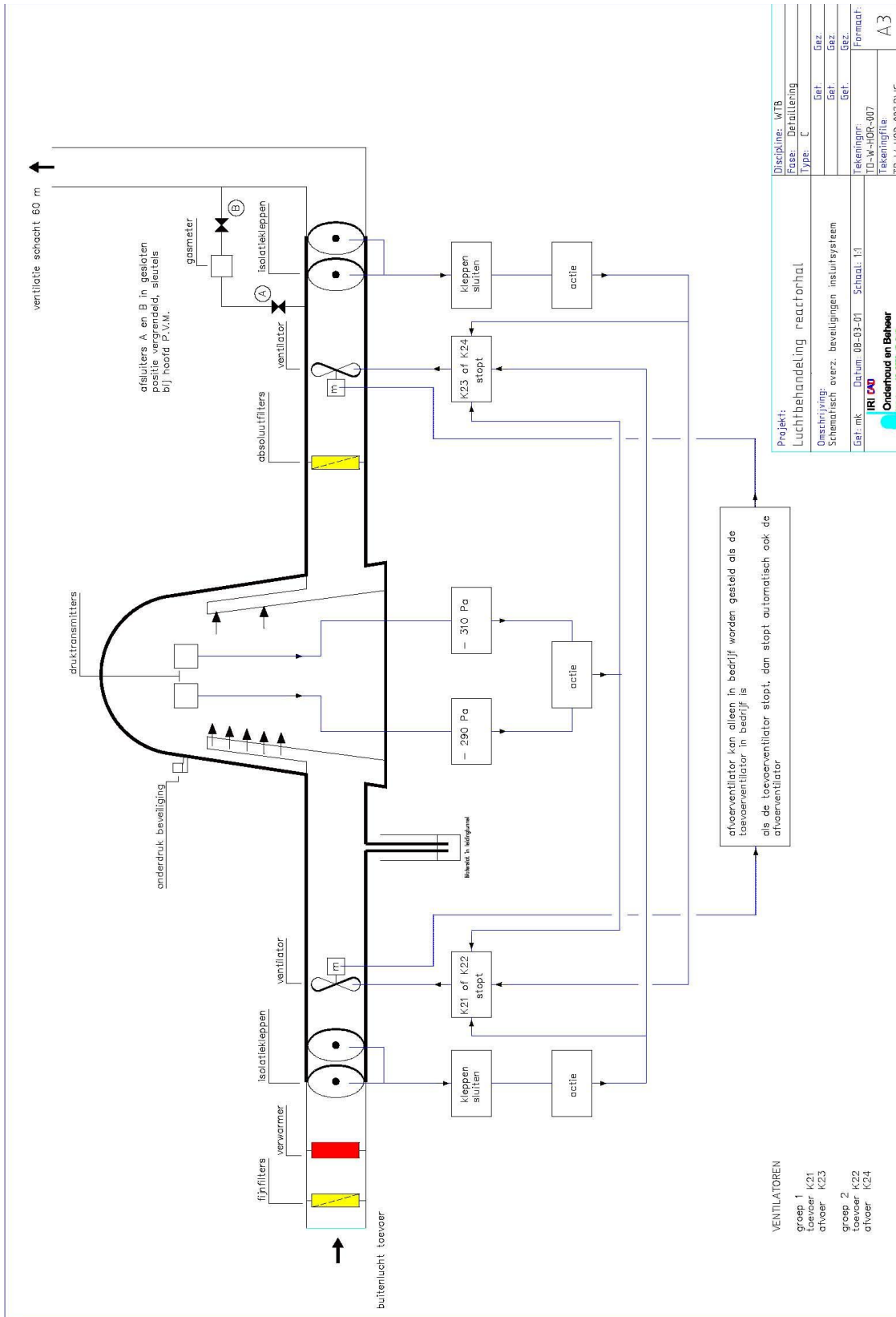

Figure 1-11: the reactor containment

1.3.8 Water clean-up and make-up system

The Reactor Institute Delft has two water supply systems: a general municipal water supply and a demineralised water supply. Both water supplies come from the public water supply system. Arrangements are made to prevent flow reversion from the RID water supply system to the public water supply system. For the benefit of the HOR, municipal water is only used in the secondary cooling circuit system. For the primary system demineralised water is produced from municipal water by using ion exchange filters. Furthermore demineralised water is supplied to separate taps in the reactor hall, labs and workshop. Figure 1-12 presents the diagram of this system

Radioactive and non-radioactive impurities in the primary water system are continuously removed by ion exchange filtering (water recycling system, Figure 1-12). Subsequently, the purified water is lead back to the pool to compensate for loss of water through evaporation. Ion exchange filtering is also applied to demineralised water of the beam tubes.

When work needs to be carried out inside the reactor pool, it can be necessary to empty one of the sections of the pool. Water from the section can be stored in the appropriate storage tank (T1). Waste water from the labs is stored in other storage tanks. When the activity of the water is below the exemption limit the water is discharged, otherwise the waste water is condensed and the residue is treated as radioactive waste.

Ultimately, in case of loss of pool water and lack of municipal water supply the storage tank T1 can be refilled rapidly by connecting the tank to fire fighting system with a connection (pipe).

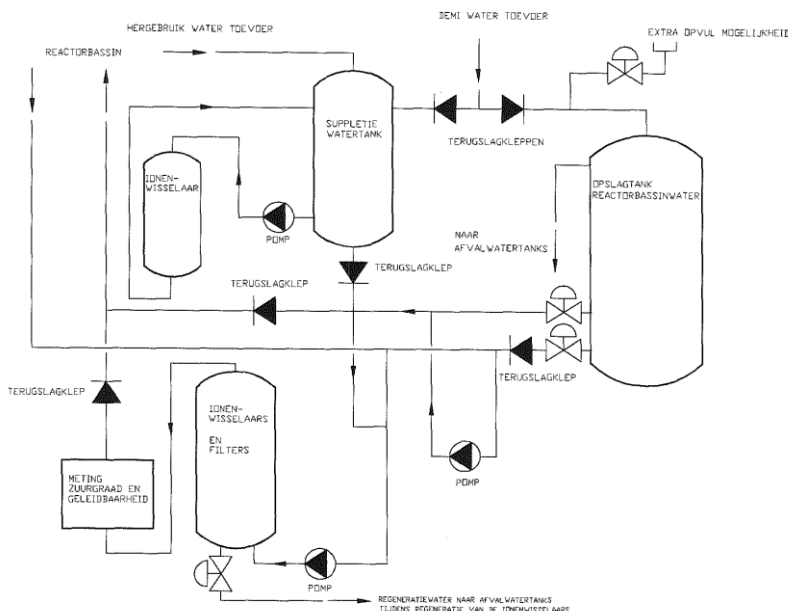

Figure 1-12: the water clean-up and make-up system

1.3.9 The electrical power system

The Electrical Power System (EPS) contains three sections fed by the public grid. In case of loss of off-site power parts of these sections are fed by the diesel generator. Emergency lighting and instrumentation are also fed through an uninterruptible power supply (batteries).

An onsite 10 kV station, fed by the public grid, supplies the RID transformers which are located on the RID site. These transformers supply the main distribution box, which in turn supplies several distribution cabinets in the institute. The internal electricity grid provides 400 V AC and 230 V AC.

Figure 1-13 presents the basic diagram of the network, whereas the parts also fed by the diesel generator are in red. Distribution cabinets numbers are displayed in the boxes

From the safety point of view an emergency power supply is not necessary, because reactor shut down and residual heat removal are independent of power supply. When there is a power failure a RSA (Reactor Scram), a RIS (Reactor Hall Isolation) and BIS (Pool Isolation) take place. However power, supplied by a diesel generator, ensures that a/o information is available and the reactor hall is easy accessible.

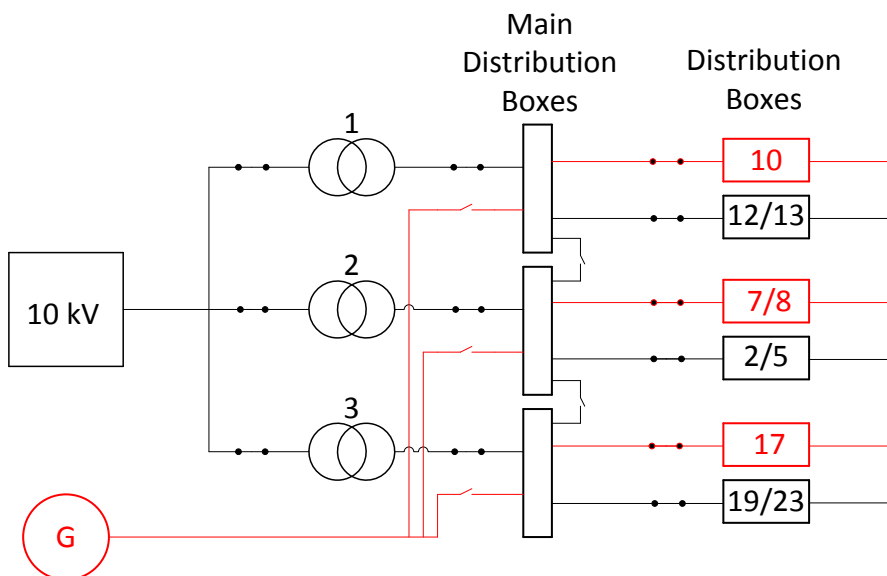

Figure 1-13: Diagram of the electrical power system

1.3.10 Experimental facilities

The HOR is provided with a large number of experimental facilities: beam tubes, a Big Sample Neutron Irradiation System (BISNIS) inside the thermal column, in core irradiation facilities, pneumatic rabbit systems and an experimental grid plate.

There are 10 beam tubes: AR, AM, AL, R1, R2, R3, L1, L2, L3 and DR-DL (Figure 1-14). The beam tubes are constructed of an aluminium inner and outer tube, surrounded by a stainless

steel tube that is imbedded in the concrete biological shield (Figure 1-15). The aluminium outer tubes are connected to the stainless steel tube by swivels. From the open top side of the pool the aluminium outer tubes are visible. The dimensions of the inner aluminium tubes are adjusted to the experiment that is placed inside the beam tube.

The thermal column is situated at the north-west side of the core. The thermal column is a cupboard constructed of steel and aluminium. On the side of the core an aluminium window of 1.4 by 1.4 m is installed. Above and below the DR-DL beam tube aluminium air boxes are installed. A nitrogen box is installed between the core and the thermal column that can be filled either with nitrogen or water in order to vary the neutron flux in the direction of the thermal column. On the inside of the thermal column, a boral plate lining is installed in order to reduce activation of the construction materials. In order to reduce the activation of the stainless steel lining a cadmium plate is installed.

On the side of the reactor hall the thermal column is enclosed by an electrically driven mobile door which is constructed of barite concrete. On the inside the door is covered with lead and boral plates. The space around the BISNIS is filled with graphite blocks. For extra shielding on the outside four concrete blocks are placed around the thermal column.

On the southern side of the large pool section the dry irradiation room (DBR) is situated. For this DBR there is an open space of 2.4 m by 2.4 m in the concrete wall of the pool. The open space is enclosed by an aluminium window. For irradiation in the DBR the core needs to be moved to the large pool section. However this facility has never been used.

The HOR is provided with two in-core irradiation facilities: the Bigbebe and the Smallbebe. Both are positioned in a beryllium reflector element. The Smallbebe consists of an outer tube containing two aluminium transport tubes. The inner diameter of the transport tubes is 16 mm. The Bigbebe consists of an outer tube containing one aluminium transport tube. The inner diameter of the transport tube is 40 mm. As the outer tubes of both in-core irradiation facilities are open there is no need of a counterweight.

There are four pneumatic rabbit systems (BP1 to BP4). Samples packed in polyethylene rabbits are transported to the core by a compressed air system. The sending/receiving station of BP1 is located in the reactor hall. The sending/receiving stations of the other rabbit systems are located in a laboratory outside the reactor hall. Leakage of pool water through this system is prevented because the guiding tubes pass the pool walls on top.

Finally the experimental grid plate is fixed to the core. Experiments and irradiation facilities can be placed onto this plate

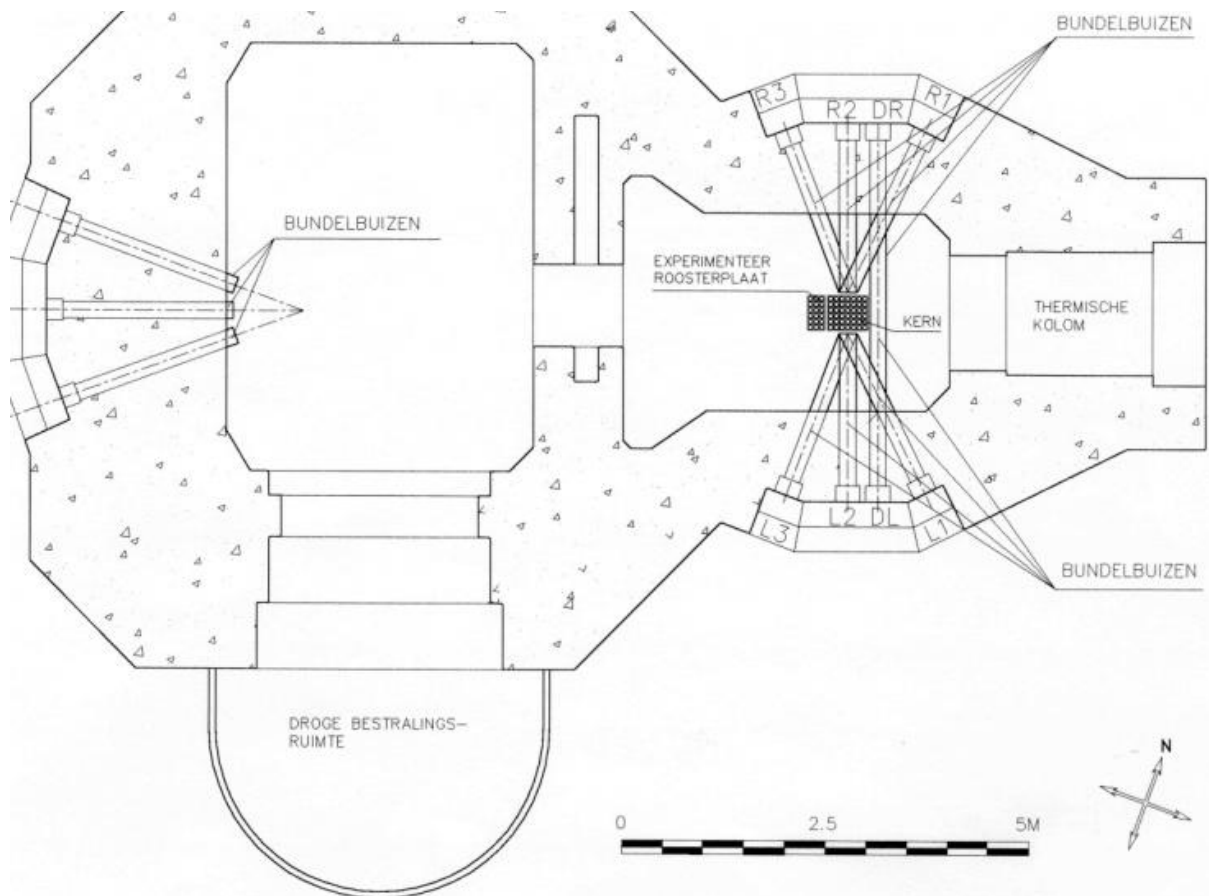

Figure 1-14: Overview of the beam tubes

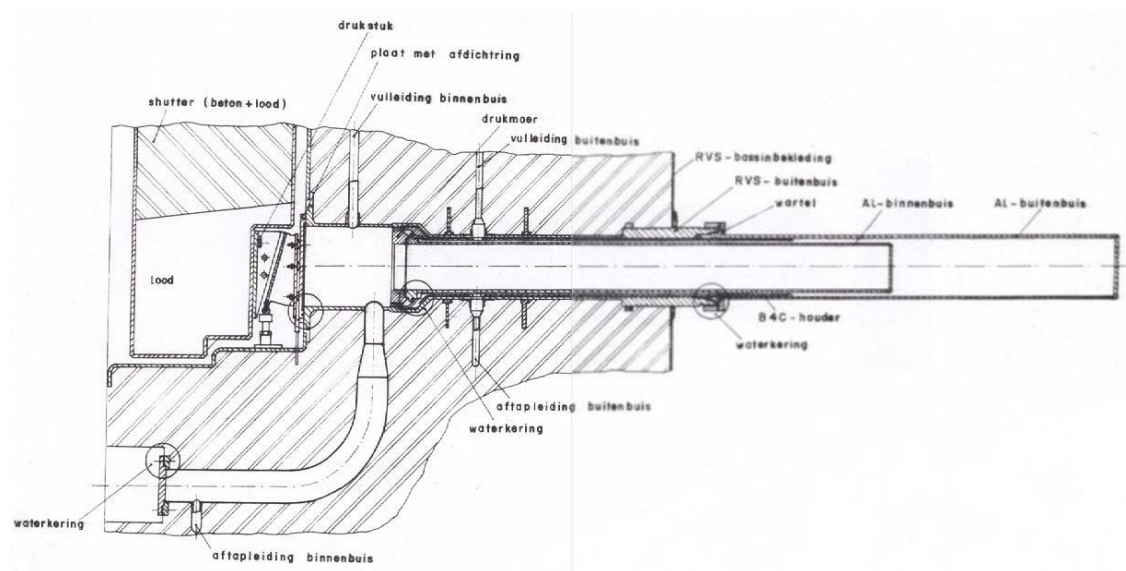

Figure 1-15: Construction of a beam tube

Next to the reactor pool, inside the reactor hall a subcritical assembly has been installed. This assembly is applied for educational purposes. The following training exercises can be performed:

- Static determination of the multiplication factor by the so-called critical assembly approach
- Axial and radial neutron flux measurements
- Source term experiments
- Neutron noise experiments like Feynman- α , and correlation measurements.

The Delphi assembly consists of two vessels on top of each other. The lower vessel is made of stainless steel and is filled with de-mineralized water before the start of an experiment. The upper acrylic air-filled vessel is used to store 168 fuel pins (maximum) that can be lowered one by one into the steel vessel to perform an experiment. Below the steel vessel, a shielding box is positioned containing a Cf-252 neutron source that can pneumatically be inserted to its experimental position.

The 168 fuels pins are positioned in a square lattice of 13x13 positions; the arrangement (pitch) of the lattice is such that k_{eff} will not exceed a maximum of 0.92.

Dose rates for the scientist performing an experiment with the source in its experimental position is less than 6.5 $\mu\text{Sv/hr}$ at the outer surface of the steel vessel; trespassers are subjected to a radiation dose rate of less than 1 $\mu\text{Sv/hr}$ when the source is in its shielding box.

1.3.11 Auxiliary systems

1.3.11.1 Fire detection/fighting

Fire detection and alarm equipment is installed in the reactor hall and auxiliary building. Fire-fighting equipment, hand extinguishers as well as hoses are available. Appendix A shows the positions of this equipment for related floors.

1.3.11.2 Central Measuring and Registration System (CRS)

The radiation and activity levels of all the building of the RID are monitored by the Central Measuring and Registration System (CRS) of the Radiation Protection department (SBD). Monitors are a/o installed in the reactor hall and auxiliary building, see appendix A. The CRS is not coupled to the reactor control & operating system and the reactor protection system.

1.3.11.3 Communication systems

For fast and efficient communication between the control room and supporting staff and services, there are several communication systems in operation:

- Telephone lines and GSMs;
- Intercom installation: the central station is based in the control rooms and several stations are installed in offices through the RID complex;

- A sound system which is operated from the reception;
- A pager system;
- Several departments including operations and technical services have walkie-talkies;
- An acoustic alarm system in case of emergency.

1.3.12 Nuclide inventory

For the nuclide inventory the following contributors can be listed:

- The reactor and pool:
that include core, spent fuel, activated/contaminated water and activated parts of reactor systems
- The experiments:
that include targets irradiated by the reactor
- Remaining sources:
 - the Delphi assembly
 - "open" sources, independent of the reactor
 - "closed" sources, independent of the reactor

The inventory of fission products in one irradiated fuel element, after long residence in the core, is 5722 TBq. The concentration of I-131 in the primary cooling water was 33 kBq/m³ at a maximum in 2011. The maximum activity produced by irradiation for 2011 was 165GBq.

"Open" sources are rated at 52 TBq; the "closed" sources are Co-60 sources classified according ISO63424 and are rated at 75 TBq. The Delphi assembly encloses a shielded Cf-252 source of maximum 18.5 MBq, while the fuel itself hardly includes any fission products (approx. 2GBq in total).

From this it can be concluded that the remaining inventory of nuclides is negligible compared to the inventory of the core.

1.4 Systems for providing or supporting main safety functions

The following safety functions are defined:

- *Reactivity control*
Shutting down the reactor and maintaining it in a safe shut down state for all operational states and Design Base Accidents (DBAs);
- *Cooling*
Providing for adequate removal of heat after shut down, in particular from the core, including in DBAs' situations;
- *Confinement*
Confining radioactive material in order to prevent or mitigate its unplanned release to the environment.

Key support functions are:

- Electrical power supply;
- Heat transfer to the ultimate heat sink.

1.4.1 Reactivity control

In this section only the reactivity control of the core and the stored fuel elements will be described. Experiments in the HOR do not contain fissile material. Therefore reactivity control does not apply for the experiments.

Reactivity addition or reduction by experiments that will be placed in or nearby the core are taken into account at core design including an efficiency check of the reactivity control system. The maximum reactivity of experiments is limited according to the OLC.

1.4.1.1 Reactivity control system of the HOR

Reactivity control of the HOR includes the combination of reactivity characteristics of the core and of the reactivity control system.

The reactivity control system of the HOR has three functions:

- The control of reactor power during operating conditions;
- Limit power increase in case of transients to prevent fast shut down;
- Fast shut down of the reactor (scram⁵) when prevention fails or accident conditions occur.

The reactivity control system consists of 4 control rods. These rods are connected to their driving mechanism by an electromagnetic device. Switching off the current results in gravity driven (passive safe) insertion of the rods into the core. The impact of the insertion relies on the neutron absorption capacity of the B₄C material of the rods.

The function of the reactivity control system is twofold: controlling the reactor power and protection (scram).

For reactivity control the following design requirements apply:

- The excess reactivity of the core should be less than 6 %;
- Shut down of the reactor should be assured by insertion of two of the least reactive control elements, while the remaining two are completely withdrawn. The shut-down margin of both these rods is checked at the start of every core cycle of the reactor

⁵ Scram: RSA Reactor Snel Afschakeling

(period between refuelling of the core). This assures shut down of the reactor even with two rods stuck;

- Reactivity addition should be limited as it is related to the limited insertion and withdrawal speed. Safety limits with regard to reactor periods should not be exceeded;
- In scram situations, drop time of the rods should be less than 0.65s;
- The temperature coefficient of fuel and moderator should be negative for the total power range of the reactor.

A reactor scram (RSA) means cutting of the exciter current of the magnet coils. A scram can be initiated when deviations from normal operation occur such as:

- Loss of primary pump;
- Spurious withdrawal of control rods;
- Loss of pool water;
- Closure of the pool isolation valves;
- Release of fair amounts of radioactive materials;
- Vertical or horizontal acceleration forces on the control rods, greater than their electromagnetic hold force.

Those deviations are detected by diverse means. In case diversity of detection systems is not applicable, redundancy of systems is applied. Various combinations of signals then will result in shut down (RSA) of the reactor. For a listing of these signals and the applicable combinations see Figure 1-10.

For instance, loss of the primary cooling pump will cause an RSA due to the combination of signals that indicate:

- loss of primary coolant flow;
- deviation of pressure difference at primary and secondary side of the heat exchanger
- (redundant) loss of position indication of the (primary system) suction head;

1.4.1.2 Reactivity control of stored fuel

Distinction is made between storage of fresh fuel elements and spent fuel elements:

Fresh fuel elements

Fresh fuel elements are stored in a dry vault. This vault is a secured cell that contains a storage rack with 30 positions. 28 Positions are available for storage of a fresh fuel element.

It is shown that the arrangement of the rack is such that k_{eff} of this vault will not exceed 0.95 even in case it is flooded by clear (non-borated) water.

Spent fuel elements

Due to their radioactive inventory, spent fuel elements have to be stored in the pool section 1 or 2, see Figure 1-7. For this storage, 12 racks that are fixed to the pool wall and 3 mobile racks are available. Four fixed racks are placed in section 1, the remaining racks are situated in section 2.

A fixed rack contains 5 positions for storage of an element; the mobile racks have two rows of 8 positions each. All racks are covered by a water layer of approx. 6 m, mainly for shielding.

The design of the racks meets the requirement that k_{eff} of the racks and the pool will not exceed 0.95 on OLC conditions that restrict storage areas in the neighborhood of the core. OLC also does not permit transport of mobile racks in case they are loaded with spent fuel.

1.4.2 Heat transfer from reactor to the ultimate heat sink

ENSREG defines the ultimate heat sink (UHS) as a medium to which the residual heat from the reactor is transferred. In some cases a plant has a primary UHS, such as the sea or a river, supplemented by an alternate UHS, for example a lake, a water table or the atmosphere.

Characteristic for those media is that they are almost infinite and in their bulk not affected by the heat discharge.

Based on the ENSREG definition the ultimate heat sink of the HOR is provided by the open air. Ultimately the heat produced by the reactor during power operation as well as the residual heat during plant shut down are discharged to the open air through the primary and secondary cooling system of which the cooling towers are the last part of the cooling chain.

An alternate ultimate heat sink, as it is indicated by ENSREG, does not exist at the RID site. However the pool, although ultimately not infinite, provides alternative cooling i.c. storage of the residual heat and can be considered as back up for the UHS; it will be dealt with under this denominator.

1.4.2.1 Existing heat transfer means

The reactor cooling system of the HOR transfers the heat generated by the reactor core to the environment. It consists of the primary and the secondary cooling system. Both systems are "open" systems as the initial part of the primary system, the pool, and the end part of the secondary system, the cooling towers, are open to the air (containment and open air respectively). Figure 1-8 presents the lay-out of both systems.

As indicated before, for power operation up to 500kW (nominal) and 750kW (maximal) cooling by natural circulation is permitted and feasible. For power operation at a higher

power level up to 2 MW (nominal) and 3 MW (maximal, with a time constraint of 1 hour per day) forced cooling is necessary. In shut down conditions dissipation of decay heat into the pool is allowed and is normal practice during the weekends or longer periods of shut down.

The primary system comprises in succession:

- *The pool*
The pool absorbs the heat produced by the core.
It is supported by the primary water clean-up system that contains circulation pumps, ion-exchangers, drain/supply tanks and a water make-up system to provide demineralized water. It is noticed that water can be pumped or even drained from the supply tank to the pool;
- *The core*
For its confinement function and heat production;
- *The suction line and suction inlet*
During forced cooling the suction inlet is lifted to the pedestal of the core by the suction force of the primary pump. At failure or stop of this pump the suction inlet will sink back by gravity into the "chair" to allow cooling by natural circulation;
- *The pool isolation outlet valves*
The valves provide isolation by closing off the outlet line of the pool during specific operational occurrences;
- *The primary pump*
The primary pump provides circulation of the coolant;
- *The control valves*
The flow control valves, placed at inlet and outlet of the heat exchanger, control primary coolant flow in accordance with power operation and assure that the pressure at the primary side of the heat exchanger is lower than the pressure at the secondary side;
- *The heat exchanger*
The heat exchanger transfers heat from the primary system to the secondary system;
- *The pool isolation inlet valves*
The valves provide for pool isolation by closing off the inlet line of the pool during specific operational occurrences;
- *The diffusor*
The diffusor distributes inlet water in the pool and provides a smooth internal pool flow.

The secondary system comprises in succession:

- *The secondary pump*
The secondary pump recirculates cooled water from cooling towers to the heat exchanger;

- *The heat exchanger*

The heat exchanger removes heat from the primary system. It provides the barrier between primary water that might be slightly contaminated and secondary cooling water, which is not contaminated, and which is partly evaporated and released to the open air;

The control valves

The control valves are placed at inlet and outlet of the heat exchanger to control secondary coolant flow in accordance with power operation and to assure that the pressure at the secondary side of the heat exchanger is higher than the pressure at the primary side;

The cooling towers

The cooling towers provide cooling of the secondary cooling water by evaporation of a part of that water in combination with forced convection of air.

Support systems of the cooling towers are:

- Sprays;
- Fan system;
- Water supply system;
- Drain system;
- Chemical control system;
- Frost prevention pump:

In case the reactor is shut down during wintertime, this pump provides circulation of the secondary water to prevent freezing.

1.4.2.2 Lay out information on the heat transfer chains

The piping of both primary and secondary system is made of stainless steel to prevent leaks.

The primary system (including the heat exchanger) is placed in the pipe-basement almost directly beneath the reactor pool. Connecting piping of the secondary system passes also the pipe-basement. Figure 1-16 shows a picture of the pipe basement. The pump-building, situated below both cooling towers, houses the remaining parts of the secondary system.

The water treatment and water make-up systems are installed in a room next to the pipe-basement.



Figure 1-16: Pipe basement

1.4.2.3 Possible time constraints for availability of heat transfer chains

There are no alternative cooling chains available; decay heat can be dissipated into the pool.

1.4.2.4 AC power sources and batteries for each chain

The electrical power supply to the HOR is provided by the following systems:

- the public grid through its 10kV sub-station;
- the diesel generator (in case of loss of off-site power);
- the uninterrupted power supply system (batteries);

In case of loss of off-site power the reactor will be shut down automatically and decay heat will be dissipated into the pool. Therefore, to assure heat removal of the core, no emergency power is needed. As a result the main circulation pumps, the ventilation system of the cooling towers, as well as the water clean-up and make-up system are not fed by the diesel generator system. For operational reasons support systems like the frost prevention pump and the air-locks are connected to that diesel generator.

1.4.2.5 Need and method of cooling equipment

Distinction is made between operation at a power level less than 750 kW and a power level beyond 750 kW.

For operation below 750 kW cooling is performed by heat transfer (convection) to the pool water that causes natural circulation through the core. Operation time is limited by the temperature constraint of 40°C of the pool water.

For operation at a power level beyond 750 kW up to 3MW forced circulation is needed to remove the heat from the core and for transfer to the ultimate heat sink. This plant state requires operation of the entire reactor cooling system. Heat is transferred from the core to the primary cooling system and from the primary to the secondary cooling system by convection. Heat is finally released to the environment through the cooling towers by evaporation of the secondary cooling water in combination with forced convection of air. Usually the reactor is operated at 2MW due to the cooling capacity, or at 3 MW for one hour per day.

1.4.3 Heat transfer from spent fuel pools to the ultimate heat sink

Spent fuel is stored in the pool without any additional confinement. This means that decay heat generated by spent fuel is dissipated directly into the pool that is part of the primary system.

Therefore, methods and systems for heat removal of the spent fuel are the same as for core cooling, see 1.4.2.

1.4.4 Heat transfer from the reactor containment to the ultimate heat sink

1.4.4.1 Existing heat transfer means

The main tasks of the ventilation system are refreshing air, heating during wintertime, controlling in- and outlet of (radioactive) airborne particles and isolation of the containment (reactor hall) during specific operational occurrences. Heat removal from the reactor hall is only performed by the refreshment action or by convection of the hall outer wall to open air. Inlet air is not cooled, nor are additional internal coolers installed.

1.4.4.2 Lay out information on the heat transfer chains

The containment system is described in 1.3.7.

1.4.4.3 Possible time constraints for availability of heat transfer chains

Not applicable.

1.4.4.4 AC power sources and batteries for each chain

Not applicable for cooling purposes.

1.4.4.5 Need and method of cooling equipment

Not applicable.

1.4.5 Confinement of radioactivity

1.4.5.1 Existing means of confinement

The ventilation system and the reactor hall form the reactor containment to reduce the release of radioactive material to a minimum by:

- Control and filtering of (radioactive) airborne material at inlet and outlet of the ventilation system;
- Isolating the reactor hall in case the concentration of radioactive material exceeds discharge limits by closing the isolation valves of the ventilation system;
- Internal circulation and filtering of the internal air in case isolation is applied.

1.4.5.2 Lay out information of the confinement system

System layout of the reactor containment is presented in Figure 1-11

At the inlet (open air to reactor hall) the system contains the following components:

- *The inlet filter*
The inlet (dust) filter prevents the reactor hall for pollution by dust;
- *The heater*
Inlet air can be heated during cold periods;
- *The isolation valves (two in line, redundant)*
These valves, operated by compressed air in a fail-safe mode, isolate the reactor hall by closing the inlet line during specific operational occurrences;
- *Inlet ventilation*
This system consists of two strains in parallel that include each one ventilator surrounded by two valves. The inlet ventilation flow is controlled by the ventilator speed;
- *The water seal*
This seal protects the reactor hall from exceeding limits for underpressure (1 kPa) and overpressure (10kPa).

At the outlet (reactor hall to open air) the system contains the following components:

- *A HEPA filter*
Outlet air is filtered by a high efficiency (HEPA; efficiency of 99.95% for particles larger than 0.3 μ m) filter to prevent release of radioactive material that is produced and/or released from the reactor into the reactor hall;

- *Outlet ventilation*
This system consists of two strains in parallel that include each one ventilator surrounded by two valves. The outlet ventilation flow is controlled by the speed of the outlet ventilator; reactor hall pressure control results from tuning of inlet and outlet ventilator speed;
- *The isolation valves (two in line)*
These valves, operated by compressed air in a fail-safe mode, isolate the reactor hall by closing the outlet line during specific operational occurrences;
- *Detection systems*
Detection systems measure radioactivity in the ventilation flow and initiate reactor hall isolation in case release limits are exceeded;
- *Isolation bypass*
One valve provides a bypass of the isolation valves in the outlet, to additional protect the reactor hall for over pressurization and disorder of the water seal.

In addition to this system a recirculation line is put in place that connects the ventilation system between outlet ventilation and outlet isolation valves at one side and the ventilation system between inlet isolation valves and inlet ventilation at the other side. In this way recirculation including filtering can be performed during reactor hall isolation.

1.4.5.3 AC power sources and batteries for each chain

Ventilators and valves of each chain are supplied by the normal electrical power system; as they are not connected to the grid that is powered by the diesel generator these components will not be available during loss of off-site power situations.

1.4.5.4 Need and method of confinement

Two plant states can be distinguished with regard to confinement namely:

- Normal operation;
- Reactor hall isolation.

Normal operation

In normal operation the reactor power can vary from shut down state to full power while the ventilation system operates normal. This means that at inlet and outlet the air flow is filtered by respectively the inlet filter, that is a normal dust filter and the outlet filter, a HEPA filter with an efficiency of 99,99% for airborne particles.

Reactor hall isolation

When the airborne radioactivity concentration is too high a RSA and a RIS occur so the reactor scrams and the gastight isolation valves of the in- and outlet close.

Isolation of the rabbit systems

The rabbit systems that penetrate the wall of the reactor hall are equipped with valves that can be closed for reactor hall isolation.

1.4.6 AC power supply

1.4.6.1 Off-site power supply

1.4.6.1.1 Reliability of off-site power supply

The off-site power supply in the Netherlands is in general reliable. The mean failure frequency of the 10kV power supply to a customer in the Netherlands is 0.27 per year. The mean duration of a power supply failure is 70 minutes. Plant specific data for the HOR is not available; therefore, this generic figure is also applicable for the loss of off-site power of the HOR.

1.4.6.1.2 Connection of the plant with external power grid

The main power supply is obtained from a 10 kV station (public grid) which is located just outside the borders of the RID site and is transported to the transformers which are located on the RID site.

Figure 1-13 presents the diagram of the network.

1.4.6.2 Power distribution inside the plant

1.4.6.2.1 Main cable routings and power distribution switchboards

The transformers supply the main distribution center, which in turn supplies several distribution centers in the institute. The internal electricity grid consists of a 400 V AC network and a 230 V AC network. These networks are divided into three sections that on their turn enclose overall 24 bus bars. From these bars all consumers are fed.

1.4.6.2.2 Lay-out, location, and physical protection against internal and external hazards

Transformers are located in the "transformer ruimte", see Figure 1-17. There are no extra precautions taken to protect these devices against hazards.

Figure 1-17 shows the lay-out of the internal electricity supply equipment.

1.4.6.3 Main ordinary on-site source for back-up power supply

In terms of reactor safety, back-up power supply is not needed. At power failure a RSA (reactor scram), a RIS (reactor hall isolation) and a BIS (pool isolation) are initiated. Safety functions are assured and require no electricity.

Nevertheless, in case of loss of off-site power parts of the three sections of the electrical power system will be fed by a diesel generator that is found in the generator building.

Fuel is supplied to the diesel generator by a day tank of 0.65 m³ with a minimum stock of 0.5 m³, backed by a main tank of 1 m³ also having a minimum stock of 0.5m³. Runtime of the diesel generator is approx. 6 hours at full load and minimum stock⁶.

1.4.7 Batteries for DC power supply

1.4.7.1 Description of separate batteries banks

An un-interruptible power supply system (UPS) with batteries is available. Its design back-up time is 1 hour.

1.4.7.2 Consumers reserved by each battery bank

Basically the UPS is meant to provide un-interrupted power to the instrumentation and the emergency lighting for the short period at switch over from public grid to power supply by the diesel generator.

1.4.7.3 Physical location and separation and protection from internal and external hazards

Batteries for the un-interrupted power provision are located next to their consumers; like batteries that are included in instrumentation boxes or emergency lighting that is fed by its own batteries.

1.4.7.4 Alternative possibilities for recharging each battery bank

Recharging is possible when external grid or diesel generator are available.

There are no alternative possibilities for recharging of the batteries.

⁶ Stress test precondition to indicate operation time frame: minimum stock is available and will not be replenished

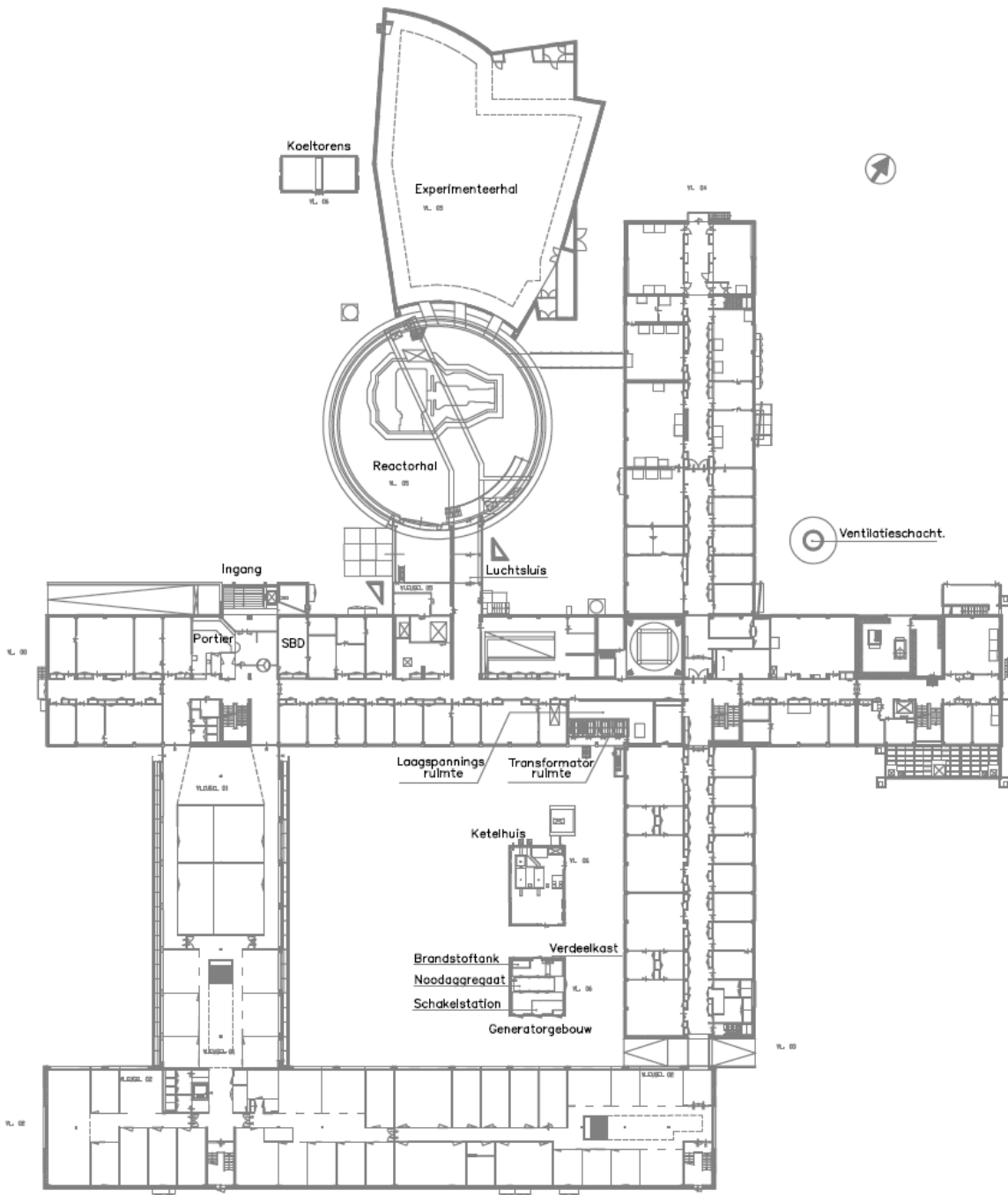

Figure 1-17: electric power supply equipment

1.5 Scope and main results of Probabilistic Safety Assessments

For its current license the HOR safety analyses report lists those events that were applicable at the time of the last license application. Probabilistic assessment is applied to categorize initiating events as design base accidents (DBA) and beyond design base accidents (BDBA). The latter are deemed highly improbable.

For control of the consequential impact of operation of nuclear reactors in relation to those safety analyses, the Dutch nuclear regulator applies criteria that have to be met.

For DBA this is related to doses criteria per event category. Categorization in this respect means classification in blocks of initiating frequencies of the events under consideration. For BDBA this is related to criteria for individual risk and risks to the society.

For the HOR enveloping initiating events are selected for both DBA and BDBA groups, namely:

1. *for DBA*

blockage of cooling channels of a fuel element during power operation (due to multiple failure of blockage detection systems) resulting in fuel damage and finally releases to the environment;

2. *for BDBA*

Air plane crash, hitting the HOR and resulting in releases to the environment.

For both initiating events accident sequences are developed resulting in the definition of source terms.

For the DBA the impact of the source term is assessed with COSYMA, a probabilistic consequence assessment code. This code includes effects like:

- Ingestion;
- Inhalation;
- Radiation of air borne radioactive materials;
- Deposit;
- Contamination;
- Site characteristics like weather conditions, surrounding of inhabitants.

For the BDBA the HOR is compared to other research reactors that assessed this event and determined its impact by application of COSYMA.

2 Earthquakes

2.1 Design basis

2.1.1 Earthquake against which the plant is designed

2.1.1.1 Back ground

The Netherlands have no earthquakes with devastating consequences, as the Netherlands are not at the edge of a tectonic plate (see Figure 2-1).



Figure 2-1 : Overview of tectonic plates; source: KNMI

Earthquakes are characterized by their magnitude on the Richter scale or by the intensity on the modified Mercalli Intensity scale (MMI) or the European Macro-seismic Scale (EMS). The magnitude on the Richter scale is a measure for the energy released by the earthquake. The intensity scales are based upon what people in the affected area feel and their observations of damage to structures around them. A rough comparison between the intensity (MMI) and the magnitude (Richter) for natural earthquakes is given in Table 2-1. The MMI and EMS scales are identical for the range of the Richter scale, up to MMI intensity IX.

Table 2-1: Comparison between MMI and Richter scale, valid at epicenter of natural earthquake

Intensity (MMI or MMS)	Observation	Magnitude (Richter)
I	Felt by very few people; barely noticeable.	1.0 to 2.0
II	Felt by a few people, especially on upper floors.	2.0 to 3.0
III	Noticeable indoors, especially on upper floors, but may not be recognized as an earthquake.	3.0 to 4.0
IV	Felt by many indoors, few outdoors. May feel like heavy truck passing by.	4.0
V	Felt by almost everyone, some people awakened. Small objects moved and trees and poles may shake.	4.0 to 5.0
VI	Felt by everyone. Difficult to stand. Some heavy furniture moved and some plaster falls. Chimneys may be slightly damaged.	5.0 to 6.0
VII	Slight to moderate damage in well built, ordinary structures. Considerable damage to poorly built structures. Some walls may fall.	6.0
VIII	Little damage in specially built structures. Considerable damage to ordinary buildings, severe damage to poorly built structures. Some walls collapse.	6.0 to 7.0
IX	Considerable damage to specially built structures, buildings shifted off foundations. Ground cracked noticeably. Wholesale destruction. Landslides.	7.0
X	Most masonry and frame structures and their foundations destroyed. Ground badly cracked. Landslides. Wholesale destruction.	7.0 to 8.0
XI	Total damage. Few, if any, structures standing. Bridges destroyed. Wide cracks in ground. Waves seen on ground.	8.0
XII	Total damage. Waves seen on ground. Objects thrown up into the air.	8.0 or larger

Seismicity of tectonic origin in The Netherlands is related to the Lower Rhine Graben and only observed in the south-east of The Netherlands. (see Figure 2-2). The most powerful earthquake was observed near Roermond in 1992 with an intensity of 7 on the EMS.

Besides earthquakes of tectonic origin, earthquakes induced by the extraction of oil and natural gas are observed; mainly in the northern part of the Netherlands. Figure 2-2 presents observed earthquakes in MMI magnitudes. Induced earthquakes are lighter, have a shorter duration and are more shock-like than natural earthquakes.

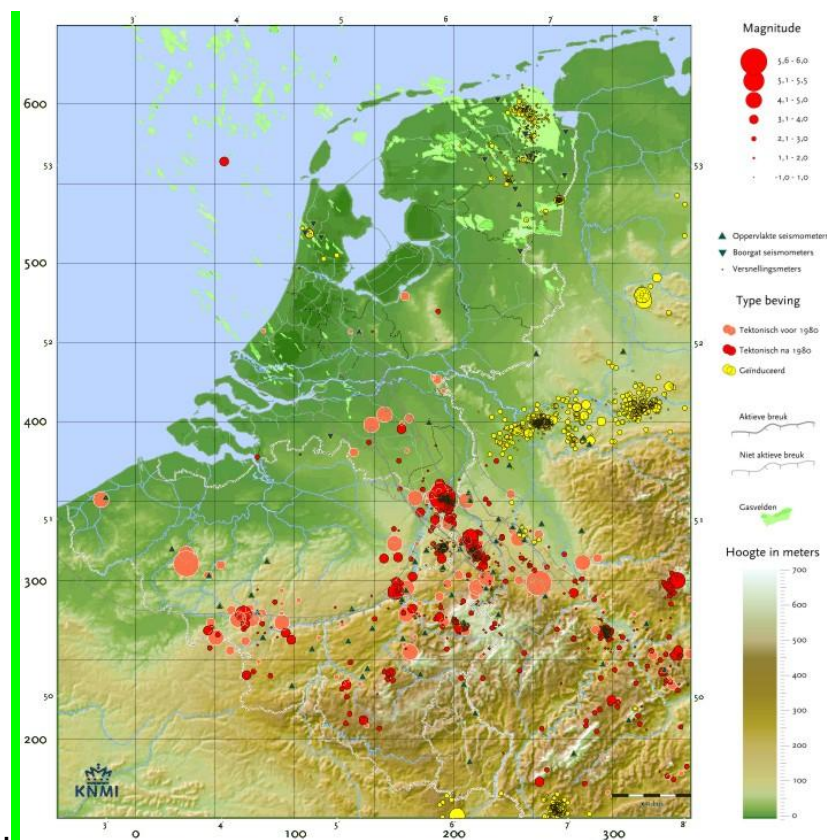

Figure 2-2: Earthquakes in the Netherlands, 1904-2004, magnitude in Richter Scale: source KNMI

This assessment is based on historical data, the location of active faults and the damping of the soil. The seismic risk map of the Netherlands - presented in "A seismic zoning map conforming to Eurocode 8, T. Crook, (Figure 2-3) - is based on natural earthquakes observed in the Netherlands, Belgium and Germany. The induced earthquakes in the northern part of the Netherlands are not taken into account. The map shows the maximum expected seismic activity with a return period of 475 years, which corresponds with an exceedance frequency of 10% in a 50 year period.

In the vicinity of Delft (within a 15 km radius) just one earthquake has been observed since 1904, see Figure 2-2. This earthquake had an intensity of 2.5 on the EMS. The seismic risk map (Figure 2-3, left hand side) shows that in the vicinity of Delft the maximum expected earthquake has an intensity of 4.5 – 5 on the EMS. This corresponds with a ground peak acceleration of 0.22 m/s^2

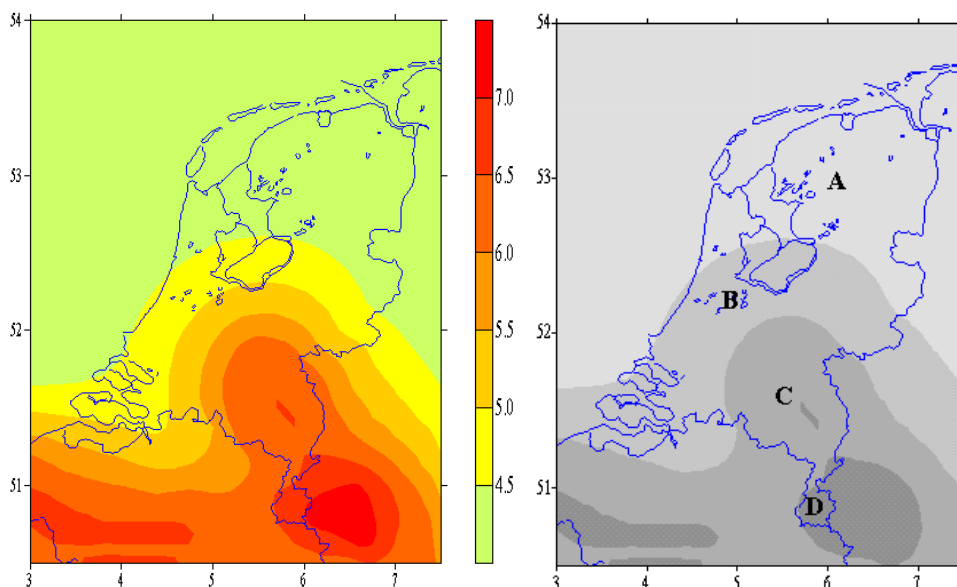

Figure 2-3: Seismic risk map of the Netherlands; left hand: intensity (EMS); right hand: peak acceleration (zones A, B, C and D , respectively 0.1, 0.22, 0.5 en 1.0 m/s²)⁷.

In areas with low seismic activity a ground peak acceleration of at least 0.1g (1 m/s²) has to be taken for nuclear facilities according to IAEA Safety Standards Series No. NS-G-3.3: "Evaluation of Seismic Hazards for NPPs".

2.1.1.2 Characteristics of the design base earthquake (DBE)

According to the Dutch building code (TGB 1990) earthquake loads can be accounted for as exceptional loads. However, the code provides insufficient data to quantify the earthquake load. Therefore, earthquake loads are normally neglected. The Dutch building code has been replaced by the Eurocode 8 in 2010. Eurocode 8 addresses seismic loads. For the application of Eurocode 8 the required data to quantify the seismic load have to be taken from the country specific appendix. NEN has not yet published the Eurocode 8 appendix for the Netherlands. Therefore, the impact of earthquakes on buildings cannot be addressed within the rules of Eurocode 8 in the Netherlands. This implies that although the present building code gives guidance on the design of earthquake resistant buildings, the data lack to

⁷ Source: Crook, T., A seismic zoning map conforming to Eurocode 8, and practical earthquake parameter relations for the Netherlands. *Geologie en Mijnbouw*, 1996. 75: p. 11-18.

determine the design base earthquake⁸. In conclusion: there is no DBE defined nor can be defined for the HOR.

2.1.1.3 Methodology used to evaluate the design base for the earthquake

Since no design base earthquake is defined, an evaluation is not possible.

2.1.1.4 Conclusion on the adequacy of the design base for the earthquake

Conclusions on the adequacy of protection against earthquakes cannot be drawn based on the previous paragraphs. The adequacy of the resistance against earthquakes will be considered in the next sections, where the impact of earthquakes on the basic safety functions is analysed.

2.1.2 Provisions to protect the plant against the design base earthquake

2.1.2.1 SSC's required for achieving safe shutdown state

The current safety philosophy behind the design of nuclear power plants against earthquakes did not exist at the time the HOR was designed and the building started in 1958. The overall safety philosophy was a conservative design with simple technical solutions and using as much as possible natural mechanisms to control the system processes after incidents and accidents (inherently safe approach). The protection of the HOR against incidents and accidents, including earthquakes, is based on the following four levels of defence (defence in depth principle):

1. Prevention of incidents through the conservative reactor design, reliable systems, quality assurance and a well-considered, plant operation laid down in procedures and instructions;
2. Detection and correction of plant operation parameters by extensive instrumentation before the system parameters exceed the operational limits. Safety (relevant) variables are detected by redundant and independent sensors for the reactor protection system RPS, the reactor control system and the alarm systems. Next to the use of interlocks in the normal process control, an additional layer between reactor control and RPS is used. This protection layer reduces the reactor

⁸ Design earthquake: The earthquake for which the safety systems of a nuclear reactor are designed to remain functional both during and after the earthquake, thus assuring the ability to shut down and maintain a safe configuration in the nuclear installation.

power, in order to bring the process back within the limits of the control loop. This additional layer limits the number of scrams by the RPS. Reactor control and RPS are independent systems;

3. Accident management through the safety systems. Before system parameters exceed the safety limits the safety systems will take corrective actions to control the accident: o.a.: SCRAM (Reactor Snel Afschakeling, RSA), Pool isolation (Bassin-Isolatie, BIS) en reactor building isolation (Reactorhal-Isolatie, RIS);
4. Mitigation of the effects of an accident for the public and the environment as laid down in the "bedrijfsnoodplan en instructies".

Based on this approach the following three basic safety functions of the reactor are guaranteed (see chapter 1) under all levels of defence:

1. *Control of reactivity*: In the reactor building the reactor core and spent fuel are present plus the (remains) of experiments. Main systems are the control rods, their drive mechanisms and the reactor protection and control system to control the reactivity of the core. Spent fuel is kept in a safe subcritical configuration by design and procedures in the reactor pool;
2. *Cooling*: The reactor core and spent fuel need cooling. The main cooling system consists of the forced or natural convection⁹ flow open loop primary cooling system, the open secondary cooling loop and the air cooling towers. Decay heat removal is performed by convection cooling with pool water;
3. *Confinement*: Confinement is provided by, in succession the fuel matrix, the fuel cladding, and the containment building. The primary system boundary plus the pool provide a semi confinement function placed between the fuel matrix and the containment.

1. Control of reactivity: The HOR has 4 control rods that are coupled to their drive trains by means of an electromagnet. Interrupting the electrical current causes the rods to drop by gravity. Two out of four rods are needed to shut down the reactor. Guide tubes ascertain that the rods drop without hindrances into the core. The scram function is tested weekly, as this is the normal way to shut down the reactor. The electrical current through the electromagnets is set at such level that the weight the electromagnets can hold is 9 kg. A control rod weighs 5 kg. This means that the rods– using the relation $F = m \cdot a$ – will drop at a downward vertical acceleration level of 17.7 m/s^2 ($a = 9 \cdot 9.81/5$). Using the IAEA guidelines in applying a factor of 1.5, this vertical acceleration corresponds with a ground peak acceleration of 11.8 m/s^2 . However, the construction of the holding mechanism is such that a small horizontal movement of the control rods is possible. A horizontal seismic

⁹ Operation mode with natural convection is limited to 750 kW core power

acceleration will result in the development of a gap between the holding surfaces of the electromagnet and the control rod. This gap will decrease the magnetic force substantially and thus resulting in a drop of the control rods at a much smaller earthquake. A more detailed evaluation should be performed to determine the seismic load at which the control rods drop. On the other hand the large stability of the pool and the core configuration under earthquake conditions guarantees to a high degree that the scram function will not be jeopardised and shut down will be successful.

2. Decay heat removal: The decay heat removal system is a totally passive system, that requires neither motive nor control power. The moment the primary pump is stopped the suction head of the primary suction line drops to its rest position by gravity. A gap between the suction head and the core support plate is created and convection cooling starts (automatically). This convection cooling is the standard way of decay heat removal after shut down of the reactor and is as such sufficient to prevent core damage (see paragraph 1.3.4). Even in case the suction head does not drop because the cantilever system is damaged by the earthquake, convection cooling with a downward flow at the sides of the core and upward flow in the centre is sufficient to cool the core. Additional water can be drained from the storage tank to the pool. The storage tank can be supplied by water from the fire fighting network. Means to this end are available. An instruction is not available and should be drafted.

3. Containment: Containment function is guaranteed by pool isolation valves (BIS) and reactor building isolation valves (RIS). Both valve types are fail-safe. The BIS valves are spring return valves. The RIS valves are closed by compressed air from a buffer. In case of a power failure these valves will be closed automatically.

2.1.2.2 Main operating contingencies

As stated above, the principle of "defence in depth" is used. Safety is guaranteed by measures and / or systems on different levels. Failure of a measure or system on one level is compensated with one on the next level. The main characteristics are a robust design of the reactor, the reactor pool and the reactor building and operational equipment in combination with the totally passive decay heat removal system, that requires neither motive nor control power.

2.1.2.3 Protection against indirect effects of the earthquake

2.1.2.3.1 Assessment of potential failures

Internal flooding

Internal water pipes that are connected to large water volumes are equipped with valves directly connected to these volumes. Worldwide industrial earthquake response experience (amongst others the Albstadt earthquake in Germany in 1978) showed in general little

damage to steel and reinforced concrete structures and mechanical equipment. Similar results were obtained in studies of earthquakes with PGAs up to 0.5g in the Pacific region (USA and Japan). The IAEA study "Earthquake experiences and seismic qualification by indirect methods in nuclear installations" IAEA-TECDOC-1333, that summarizes various studies of earthquake response concluded that piping systems survive earthquakes very well.

Details about the internal flooding scenarios and its consequences are addressed in Chapter 7 of this report (Other Extreme Events).

Internal fire

Protection against the risk of fire is ensured by a proper design of the safety systems and proper housekeeping. Inspection walk-downs with the local fire brigade are held on a regular basis as part of the "gebruiksvergunning" (operating license). The fire-fighting systems are supplied with water from the public water supply system. These systems are not seismically qualified. Details about the consequences of internal fires are addressed in chapter 7 of this report (Other extreme events).

High energy equipment

The only high energy equipment that might be present in the reactor are high pressure gas cylinders. Placement of these cylinders in the reactor building is very restricted. If present, they are secured to the wall of the reactor building.

Loss of pool water

The IAEA TECDOC-1333 that summarizes various studies of earthquake response concluded that piping systems survive earthquakes very well. All piping penetrating the reactor pool bottom has jacket pipes with bellows between the pool bottom and the first isolation valve, creating a double walled containment. The primary piping is lying on the floor of the basement beneath the pool, which gives the primary piping a large insensibility to damage due to seismic loading. The layout of the primary system is tailored to absorb the differences in thermal expansion. Thermal stresses are the dominating loads in the pipes. For the HOR stress levels in the primary piping will only be slightly increased due to an additional seismic load. The connections between the various components of the primary cooling system are flexible enough to accommodate the seismic loads that can be expected for the HOR. In conclusion, based on expert assessment, a LOCA caused by earthquakes with magnitudes to be expected in the Delft region is very unlikely.

Another possibility to loose pool water is damage to the pool itself. The resistance of the reactor pool is assessed in paragraph 2.2.1.1.

Loss of pool water is dealt with in chapter 5 (5.1.2.5)

Loss of ultimate heat sink

In case of an earthquake the reactor will be shut down and the pool functions as alternate UHS. The capacity of the pool is more than sufficient to remove decay heat (see chapter 5). Loss of pool water means loss of alternate heat sink, dealt with in chapter 5 (5.1.2.5). Details about the cooling modes are presented in that paragraph. Possible loss of the UHS is discussed in paragraph 2.2.1.

2.1.2.3.2 Loss of external power supply

A safe shut down of the reactor does not need external power. Shutting down the reactor and maintaining a safe shutdown state is a completely passive process.

2.1.2.3.3 Situation outside the plant

Based on the expected earthquake intensities, damage outside the plant can be expected. As the HOR can maintain its safe shut down state for a long time, see chapter 5, without outside assistance the impact of the situation outside the plant will be small.

2.1.2.3.4 Other indirect effects (e.g. fire or explosion)

Possible effects of earthquake induced (external) fires and explosions are addressed in chapter 7. The reactor building is founded on piles, which reach to a deep lying load bearing layers (sand, clay). The same is true for the stack. Liquefaction poses no direct danger to the reactor building. However, the ground at the surface around the reactor building is soft and susceptible to liquefaction. If liquefaction in the area around the reactor building occurs, connections to outside utilities like electricity, gas, water, and sewer system will fail.

2.1.3 Compliance of the plant which its current licensing basis

2.1.3.1 Processes to ensure needed faultless condition

Maintenance and operating procedures are in place to ascertain the proper functioning of structures, systems and components. No specific measures exist for earthquake situations, other than the maximum hold current through the electromagnets of the control rod couplings.

2.1.3.2 Processes to ensure mobile equipment preparedness

As there are no specific measures to deal with earthquake situations, there are no procedures that deal with mobile equipment and supplies that are planned for use, nor are those features available or external on stock. General procedures are in place to ascertain safe shut down and general safety.

2.1.3.3 Potential deviations from licensing basis

No deviations with respect to the licensing base have been established.

2.2 Evaluation of safety margins

2.2.1 Range of earthquake leading to severe fuel damage

The HOR contains only a limited amount of nuclear material. Fuel damage can occur in several ways:

- The reactor pool gets damaged by an earthquake;
- A leakage of pool water that cannot be isolated occurs as a result of an earthquake;
- The stack falls onto the containment;
- Core configuration is disturbed;
- Configuration in spent fuel racks is disturbed.

The first two cases could result in LAHS (see chapter 5 for details). The seismic resistance of the pool can be evaluated based on existing mechanical calculations. LOCAs that cannot be isolated are not to be expected (see paragraph 2.1.2.3.1).

In the last cases structural damage may be inflicted to the fuel elements or the cooling flow may be disturbed. This may occur when the stack falls onto the containment and large pieces of debris of the stack break through and fall on the core or spent fuel causing damage and/or preventing cooling.

For the stack no calculations are available that give an indication of its strength. Also no indications of the containments' strength for this kind of loads are known. It is therefore not possible to evaluate the seismic resistance of the stack and related missile impact to the containment.

2.2.1.1 Reactor pool

For the reactor pool and the structures within the pool the following failure modes are possible:

1. Vibrations in the underground are transferred to the concrete foundation through the ground pressure;
2. The pool walls could get damaged;
3. The load on the pile foundation could become eccentric;
4. Debris falls into the pool;
5. The stack falls onto the containment, breaks through and debris falls on the core resulting in core damage.

2.2.1.1.1 Ground pressure

The force that is required to accelerate the structure of the HOR, has to be transferred by the ground pressure to the foundation. With a simple static evaluation the force required to accelerate the pool is estimated. The calculation is based on the criteria formulated in NVR 3.1, the Dutch nuclear Rules and Regulations a/o on seismic and SSG-9 the IAEA- "Seismic Hazard in Site Evaluation for Nuclear Installations". The total mass of the concrete and water is 2320 tons. The exerted force is:

$$F = m * a * \text{safety factor}^{10} = 2320 * 1 * 2 = 4640 \text{ kN}$$

The maximum counter pressure of the soil is estimated to be 2727 kN. This yields a margin of safety of $4640/2727 = 1.7$. The limiting earthquake (margin of safety equals 1) is an earthquake with an acceleration of $2727/2320 = 1.2 \text{ m/s}^2$ or 0.6 m/s^2 when taking the safety factor of 2 into account. Both values are far above the value of 0.22 m/s^2 that can be expected based on the earthquake risk map (see figure 2.3).

In the evaluation above a number of simplifications have been made. The resistance of the tunnel beneath the reactor pool is neglected as well as the sideways support by the abutment piles of the foundation.

2.2.1.1.2 Pool walls

The pool walls are 2.5 m thick at the location of the core and contain reinforcement. The pool walls will not be the part to fail first due to horizontal seismic accelerations. The pile foundation of the pool will fail first. However, as shown in the paragraph above this is very unlikely to happen.

Seismic loads can induce sloshing in water pools. Large waves can overflow the pool rim and the pressure of the waves may damage structures standing in the water. However the seismic loads expected for the HOR can only cause a small rippling at the water surface of the pool. No damage due to pressure waves will occur to the structures in the pool.

2.2.1.1.3 Eccentric loads on the pile foundation

In order to estimate the resistance of the pile foundation against Earthquakes, the known resistance against wind loads is used, because the resulting load type acting on the foundation is the same in both cases. In case of an earthquake the horizontal ground

¹⁰ Dynamic safety factor of 2 placed on the acceleration of 1 m/s^2 , to account for dynamic behavior in the static calculation

pressure does not act at the centre of gravity of the pool. As a consequence a moment is acting on the pile foundation. Wind loads acting on the reactor building also cause a moment acting on the pile foundation. Both loads are calculated in section 2.2.2. The eccentric pile loads due to a seismic load are much smaller than the eccentric pile loads due to the wind load acting on the reactor building. Because the margin of safety with regards to eccentric pile loads due to the wind load is large, it can be assumed that eccentric pile loads due to an earthquake will not yield problems.

2.2.1.1.4 Falling debris

The reactor hall of the HOR does not contain structures that can fall in the pool and onto the core. The only objects that can fall are objects that are temporarily brought into the reactor hall. Good housekeeping rules can prevent failure due falling debris. The edge of the pool should be kept free from objects.

2.2.1.1.5 Stack

The stack is standing close to the reactor building. No seismic evaluation has been performed for the stack. If the stack falls onto the reactor building failure of the containment cannot be ruled out. Through the failed containment debris from the stack might fall in the pool and onto the core. In this scenario core damage following containment damage cannot be excluded. It is recommended to perform a seismic evaluation for the HOR stack as well as to check the resistance of the containment against impact of debris.

2.2.1.2 Stability of core configuration

The core is hanging at the movable bridge across the pool. As a consequence of the seismic loads feasible for the HOR the bridge, including the core, cannot derail. The stability of the total structure is also enhanced because the core is hanging in the pool water, which acts as a damper for seismic vibrations. Loss of core configuration impairing cooling of fuel elements in the core is therefore not to be expected.

2.2.1.3 Stability of storage racks

Two types of storage racks are applied in the HOR pool. The first type is fixed to the walls and will only fail if the pool walls fail. The second type is standing on the floor of the pool. The worst case incident for this type of storage rack is toppling. However, this type of storage rack has a larger diameter than height, which gives it an inherent stability against toppling.

2.2.1.4 Safety of dome crane during an earthquake

It is unlikely that the containment crane will drop from its support. The support of the crane is an integral part of the dome structure. The crane falling of its support is only possible if

the dome structure deforms excessive or completely fails. This will not happen at the earthquakes that can be expected in the Delft region.

Breaking of the crane girders during an earthquake is also unlikely. This requires an overloading of the girders. Cranes are designed with large safety margins incorporated. The earthquakes that can happen cannot cause an overload in the crane girders.

The crane trolley does not derail. The large flanges on both sides of the wheels prevent this. Moving apart of the crane girders is also unlikely.

The staircase to the central turn pivot is supported at the two ends: the turn pivot in the centre of the dome and to the end points of the crane girders by means of welded plate supports. The design looks robust, but it should be checked whether it can bear the total mass of the staircase and the stability of these connections during an earthquake should be investigated in more detail.

2.2.2 Range of earthquake leading to loss of containment integrity

The seismic resistance of the containment can be evaluated based on existing calculations. The maximum peak ground acceleration that can occur at the HOR site is 0.22 m/s^2 according to data from KNMI. The area in the vicinity of the HOR is considered an area with a low seismic risk. According to the Dutch NVR 3.1 and the IAEA guideline SSG-9 (see 2.2.1.1.1) nuclear facilities in an area with low seismic risk have to be designed to withstand an earthquake with a peak ground acceleration of at least 1.0 m/s^2 .

The evaluation of the strength of the containment against earthquakes is based on the design of the containment against wind loads. The containment is designed for a wind load of 1250 N/m^2 . The drag weight of the containment is specified: 120 kg/m^2 . Based on a simple static evaluation, utilizing a safety factor of 2 on the maximum seismic acceleration of 1 m/s^2 the maximum seismic force acting on the containment is 240 N/m^2 . Compared to the wind load this gives a safety margin of 5.2.

The earth-quake resistance of the containment isolation valves is unknown. However as long as the fuel is not damaged, loss of containment is not a problem.

2.2.3 Earthquake and consequent flooding exceeding design basis

In chapter 3 (external flooding) it is shown that an earthquake induced flooding is not to be expected on the Dutch coast.

2.2.4 Measures to increase robustness of the plant against earthquakes

Potential cliff-edge effects

Potential cliff-edge effects induced by an earthquake are related to damages to the HOR that result in loss of cooling of the fuel elements:

- Leakage of the pool through the walls or through connected piping (especially below top of fuel);
- Damage of core or spent fuel by debris from the stack, causing loss of configuration and thus loss of coolant flow;
- Control rods that are stuck.

Measures for improvement

Whether or not these potential cliff-edges are real cliff edges cannot be determined as a result of lack of information. Therefore it is recommended to elaborate these issues for their feasibility and decide later on additional measures e.g.:

- The cooling capabilities in case of loss of pool water should be investigated (see chapter 5 for more details);
- A seismic evaluation of the HOR stack and the impact resistance of the containment is recommended;
- The magnetic holding force of the control rods should be tested to ascertain the assumption that drop of these rods into the core will occur in case of the type of earthquakes to be expected in the Delft region;
- Although means to supply water to the storage tank are available, an instruction is missing and should be drafted.
- Evaluate the resistance against earthquake loading of the two support points of the staircase to the central turn pivot of the crane.

3 Flooding

This chapter describes the outline of the analysis of the HOR with respect to flooding conditions from external sources. As the HOR is located in a polder, that is part of dike ring 14 (see Figure 3-3), the flooding conditions considered are flooding of the polder as a result of dike failure, caused by high tides, storm surges or high water levels in the rivers and high water table (ground water level).

3.1 Flood sources

3.1.1 Flooding from the North Sea

3.1.1.1 High tide and storm surges

A high tide, possibly in combination with a storm surge may lead to flooding of dike ring 14. Although given the design level of the coastal defense against flooding and the location of the HOR (15 km from the sea) the probability of flooding caused by high tides/storm surges is very low. However it cannot be completely excluded, given the fact that the ground level of the HOR is below mean sea level.

3.1.1.2 Tsunami

From history, there is evidence of only a few tsunamis in the West European region. These tsunamis are discussed shortly and the possible impact of a tsunami on the Dutch coast is discussed

1. ***Storegga Slide (approximately 8200 years ago)***

Large parts of the now submerged North Sea continental shelf (now part of the North Sea between the Netherlands and UK) were flooded by the Storegga Slide tsunami, one of the largest tsunamis known for the Holocene, which was generated on the Norwegian coastal margin by a submarine landslide. The characteristics of the wave triggered by this ancient event were simulated. A calculated initial wave height of 3 m at the source of the model results in maximum deviations of about 0.5 to 0.7 m at the tidal gauges in the German Bight. It would take approximately 8.5 hours for the first wave to reach the German coast line.

Geological models suggests that for a tsunami such as the one following the Storegga slide, another glaciation (time scale ~100,000 years) is needed to re-establish the conditions required for a similar failure at that location. However, there are other sections of the neighboring continental shelf that have the potential for a landslide, possibly triggered by an earthquake.

2. ***Lisbon Earthquake (1755)***

The tsunami triggered by the 1755 Lisbon Earthquake reached Holland, although the waves had lost their destructive power. Waves at the origin had an amplitude of 1 m. After 5 to 8 hours waves with a height of 0.8 to 2 m reached the Cornwall coasts with localized amplification enhancing the elevations to approximately 4 m. A tsunami entering the North Sea from the English Channel will not have any severe consequences in the North Sea, since this wave will be reflected and diminished in the English Channel.

3. ***Dogger Bank earthquake (1931)***

This earthquake, which measured 6.1 on the Richter scale, caused a small tsunami (wave amplitude at the origin 1 m). After 1 to 2 hours waves with a height of 0.8 to 2 m reached the Yorkshire and Humberside coasts.

Possible impact at Dutch coast

In a study performed in 1993, it was concluded that a hypothetical tsunami would result in a maximum elevation of the water level of 1.4 m along the Dutch coast. This is below the observed normal high tides. Based on this result the risk of flooding due to a tsunami is regarded as non-existent. This conclusion is supported by more recent research. For the German Bight it was concluded in 2007 that Cuxhaven will be protected by the shallow North Sea from the catastrophic impacts of a hypothetical tsunami. Waves of 0.5 m are expected. The same study showed waves of approximately 2 m at IJmuiden. As far as the Belgian coast is concerned, research concluded in 2005 that a hypothetical tsunami will not grow to an amplitude of several meters but to a maximum of 0.7 m, due to damping in the relatively shallow North Sea.

In conclusion: a tsunami will have no impact on the HOR.

3.1.2 Flooding of the rivers

From landside the polder could be flooded either by high water in the river Rhine or the "Nieuwe Waterweg" which is located approx. 12 km to the South of Delft. In the latter case the high water level can also be caused by high tides/storm surges on the North Sea that disturb the normal discharge of the river. However flooding of either of these rivers or a combination are part of the design criteria of dijkkring 14. In the "Nieuwe Waterweg" for instance a storm surge barrier will be closed on specific high tide conditions.

3.1.3 Flooding by water-table

As the ground level of the HOR site is under sea level (-1.2 NAP, see paragraph 3.2), the water table level is kept artificial below this level. A protracted loss of the pumping activity will ultimately end in flooding of the site. However, this is a slow process with ample time to

restore pump capacity, before the water levels reaches values that threaten the safety of the HOR. Therefore this scenario will not be further considered.

3.2 Design base

In the design and licensing process of the HOR the possibility of flooding has been taken into account, as the polder and thus the institute's ground level ("maaiveld") is below mean sea level (NAP): At the location of the HOR the ground level is approximately -1.2 m NAP. The design against flooding is elaborated in the Safety Report. Figure 3-1 shows the height contours around Delft. The location of the reactor institute is marked with the label "AHN1: -1.2 m". Figure 3-2 shows the same for the close vicinity of the institute.

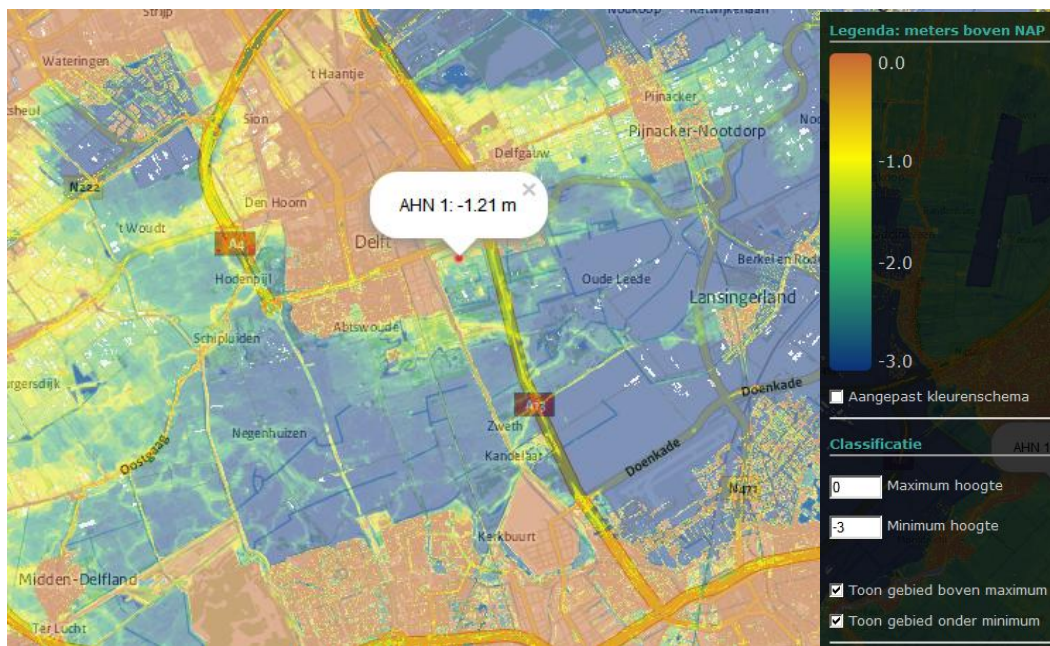

Figure 3-1: Ground level around Delft (source): het Actueel Hoogtebestand Nederland (AHN)

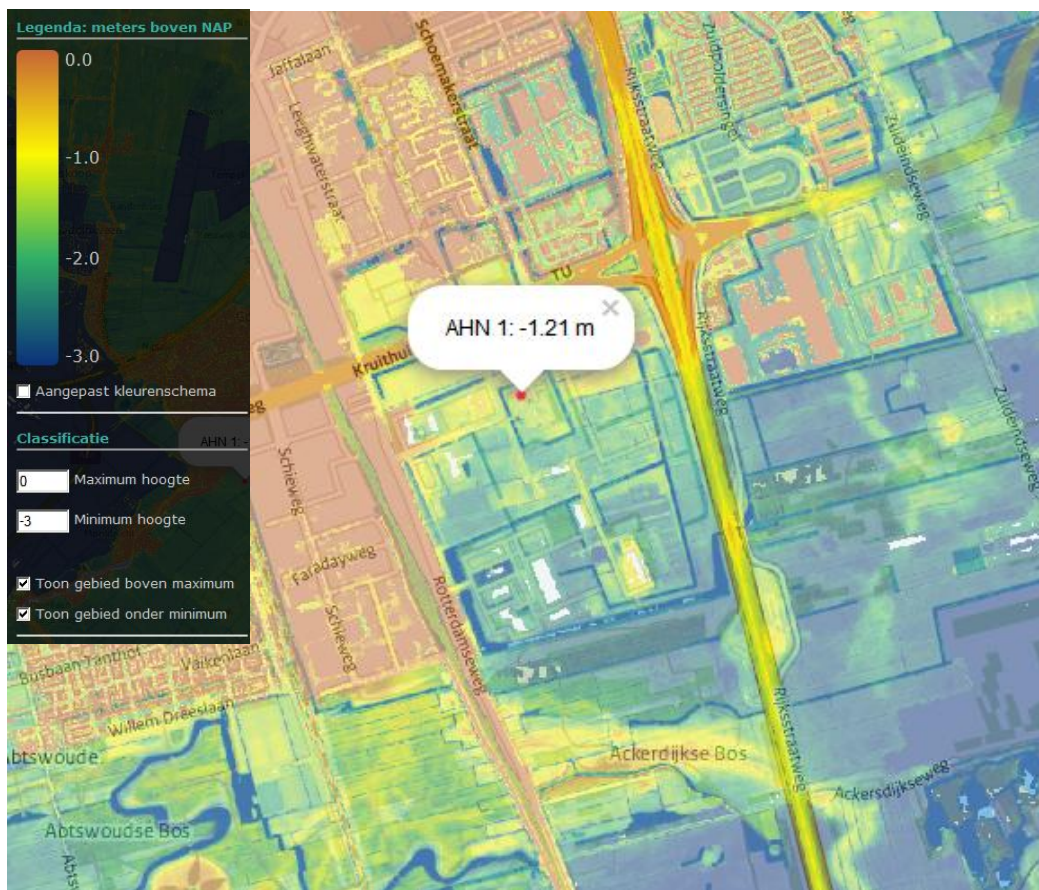

Figure 3-2: Ground level around the HOR site (source: Het Actueel Hoogtebestand Nederland (AHN) detail

3.2.1 Flooding against which the plant is designed

The Safety Report states that the water in the polder where the HOR is situated can reach a level of 1.2 m NAP (+2.4 m above ground level) under the most severe circumstances. The reactor building, including its doors, is designed to withstand the single sided water pressure that arises from this flooding height.

The other buildings, including those housing the cooling and electrical systems are not specifically designed against flooding. The control room in the control room building however is situated at 10.5 m above ground level and is thus protected against flooding. The no-break batteries for instrumentation (1 hour capacity) are located in the control room. The alarm staff room is situated on the ground floor of the main building (0,3m NAP).

During a possible flooding of the HOR site access to the reactor hall is secured, as the second personnel lock is also located at the same level as the control room (10.5m above ground level).

3.2.1.1 Characteristics of the design base flood (DBF)

The design based flood is only characterised by the maximum credible water depth of 2.4 m above ground level (+1.2m NAP) as described in the Safety Report.

However, it is to be expected that given the inland location of the reactor far from the outside dikes of dike ring 14, the water level in case of a flooding is a static load; the water rises rather slowly and no significant wave action has to be expected.

3.2.1.2 Methodology used to evaluate the design base flood

Although the Safety Report and design documentation give little information on the background of the design level an evaluation is still possible. Recent literature, like the "Overstromingschade I Dijkkring 14", J.P. van Schroyen Lantman and the "Coördinatieplan dijkkring 14, RWS, on flood protection, flood risk assessment, and evacuation planning gives flooding scenarios for dike ring 14. Figure 3-3 gives an overview of this dike ring. There are two sources of water that potentially threaten dike ring 14: the North Sea and the river Rhine. For both flood sources worst case scenarios are developed and resulting water levels inside dike ring 14 are calculated.



Figure 3-3: dijkkring 14, rode lijn; source: Coördinatieplan dijkkring 14, RWS

North Sea scenario

In case of a storm surge on the North Sea the worst case scenarios are those with multiple failure of the dike ring. In figure 3-4 the result of a fourfold breakthrough of the North Sea can be seen. At the location of the HOR the resulting flood height is below 2 m, which is below the design level of the HOR of 2.4 m.

River Scenario

During flooding of a river multiple breakthroughs are not to be expected, even in a worst case scenario. The reason for this is that contrary to flooding from the sea, the water level in the river will drop in case of the first break through, which will lessen the pressure on the river dike and preventing further failure. Figure 3-5 shows the results of flooding analyses. As the water will not reach the Delft area, it will be clear that the river scenario is no threat to the HOR.

Water table scenario

In case the artificial level of the water-table cannot be maintained water will rise to approximately 0m NAP. This means that flood height will become 1.2m, which is below the design level.

3.2.1.3 Conclusion on the adequacy of protection against external flooding

The North Sea scenarios are the flooding scenarios determining the maximum credible flooding height. These scenarios do not challenge the design level of the plant.

3.2.2 Provisions to protect the plant against the design base flood

3.2.2.1 SSC's required for achieving safe shutdown state

To reach and maintain a safe shut down state three main safety functions have to be met. This section gives a brief overview of the safety functions and the SSCs (The SSCs are extensively described in chapter 1):

1. *Control of reactivity*: In the reactor building the reactor core and spent fuel are present plus the (previously used) experiments. Main systems for controlling the reactivity of the core are the control rods, the control drive mechanisms and the reactor protection and control system. Spent fuel is kept in a safe subcritical configuration by design and procedures;

2. *Cooling*: Main cooling systems are the forced or natural convection¹¹ flow open loop primary cooling system, the open secondary cooling loop and the air cooling towers. Decay heat removal is performed by convection cooling with pool water;
3. *Confinement*: Confinement is provided by successively the fuel matrix, the fuel cladding, and the containment building. The primary system boundary plus the pool provide a semi confinement function located between the fuel matrix and the containment.

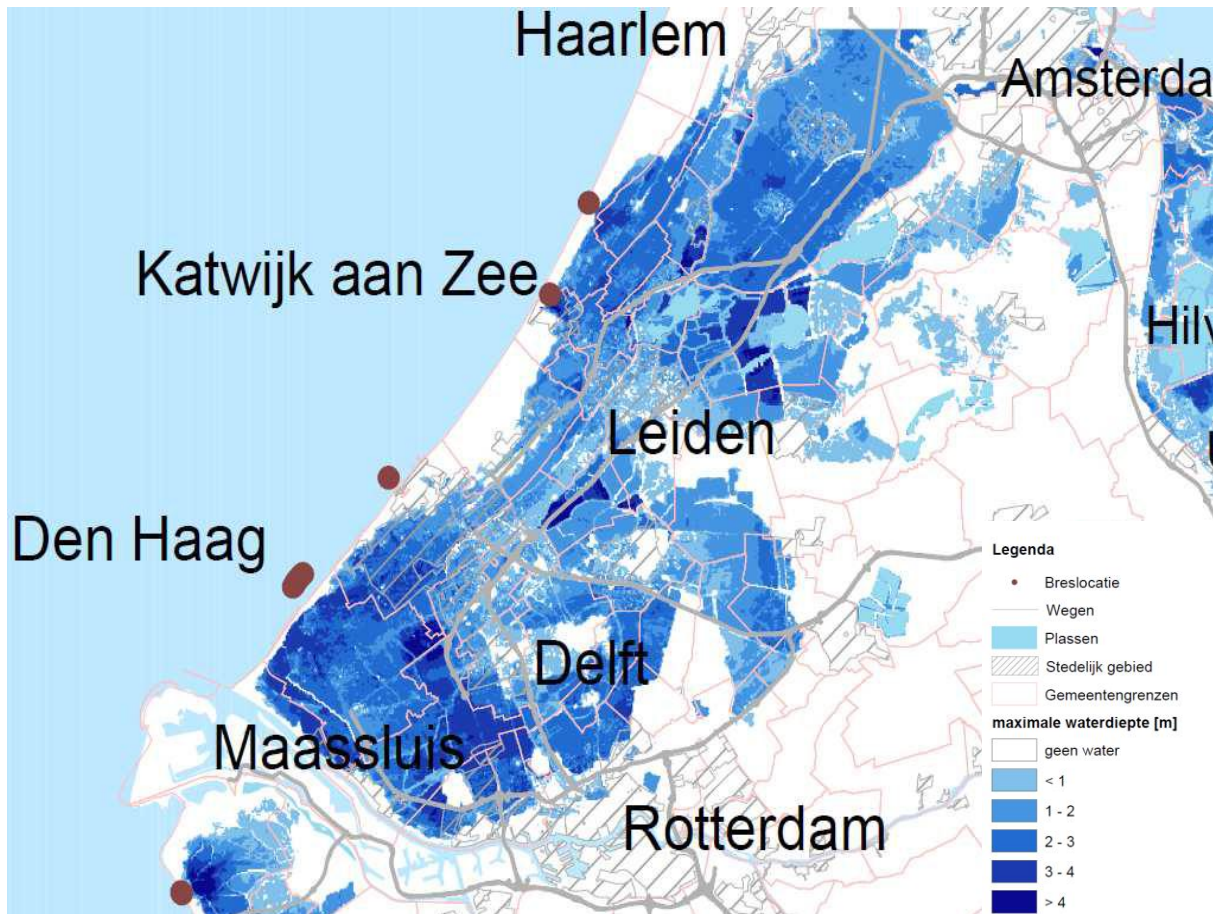

Figure 3-4: Worst case case scenario North Sea; source: Coördinatieplan dijkkring 14, RWS

¹¹ Operation mode with natural convection is limited to 750 kW core power

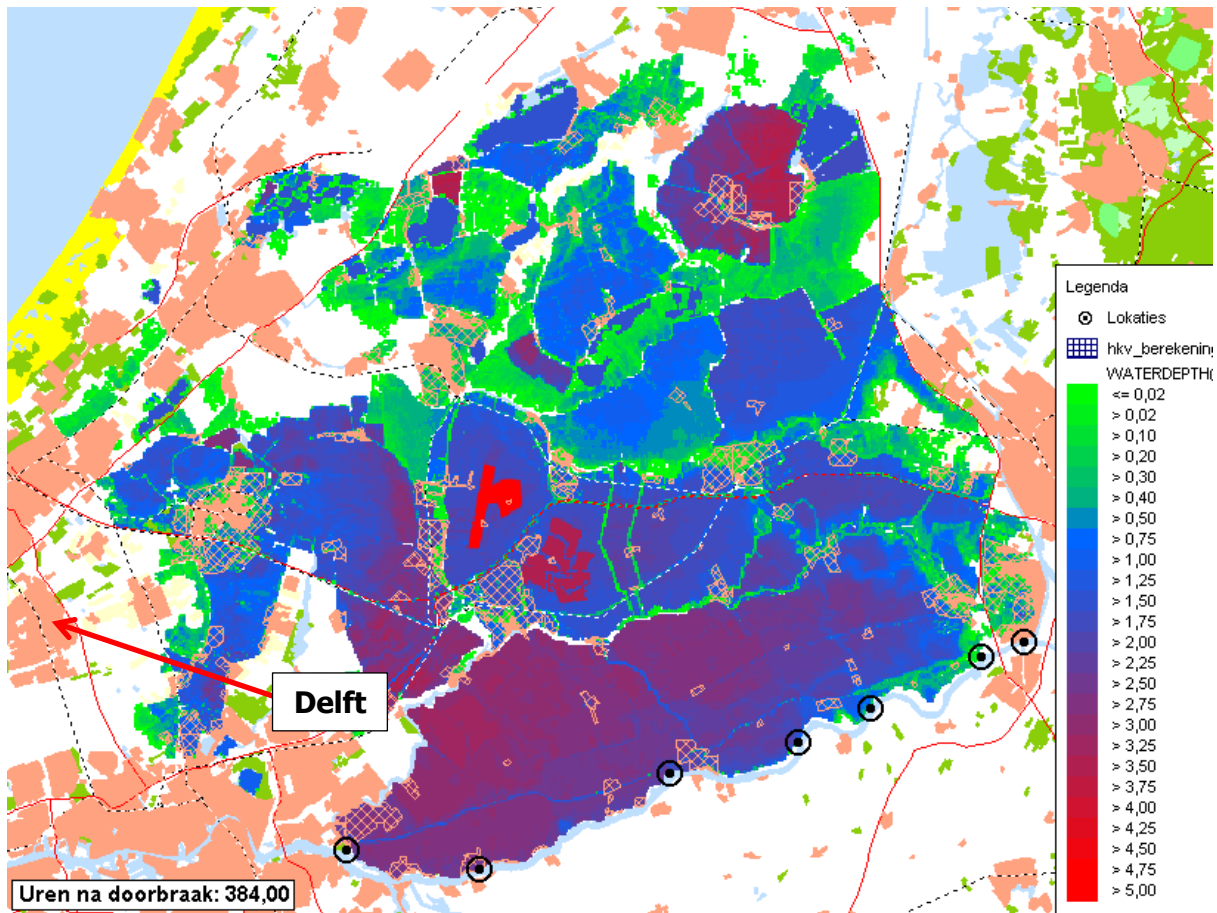

Figure 3-5: Worst case scenario River: source: Coördinatieplan dijkkring 14, RWS

3.2.2.2 Main design and construction provisions to prevent flood impact

The main design and construction provision to prevent flood impact is the combination of a watertight containment up to a flooding depth of 2.4 m above ground level (+1.2 m NAP) and the passive cooling behaviour of the HOR.

In case of power failure – which is very likely to occur in case of a major flooding - the reactor will scram automatically, as the electromagnets of the control rod drives will fail to hold the rods in that situation. As a result the rods will fall into the core and the core becomes sub-critical within 1 second.

The decay heat removal system is a totally passive system that requires neither motive nor control power. The moment the primary pump is stopped the suction head of the primary suction line drops to its resting position by gravity. A gap between the suction head and the core support plate is created and convection cooling starts. Convection cooling is the standard way of decay heat removal after shut down of the reactor and is sufficient to prevent core damage (see paragraph 1.3.2).

In conclusion, in case of a normal shut down, loss of power or loss of forced primary flow the reactor is automatically brought into a safe shut down state.

3.2.2.3 Main operating provisions to prevent flood impact

There are no particular operating provisions in case of an anticipated flooding, however in case a possible flooding is expected the HOR will be manually shut down.

3.2.2.4 Situation outside the plant

In case of a flooding of the polder the HOR is located in, a large part of the province of Zuid-Holland between Rotterdam, Den Haag and Leiden will be flooded as well, see Figure 3-4. The site will be difficult to reach. Even as the HOR site itself, due to its relatively high elevation, is not surrounded by water, Loss of Offsite Power may occur. In this case the HOR site relies on the diesel generator for power. As the diesel generator is not protected against flooding, one cannot rely on it. This does not pose a problem as the design of the HOR is such that safe shut down can be reached and maintained without electrical power.

3.2.3 Plant compliance with it's current licensing basis

3.2.3.1 Processes te ensure needed faultless condition

Maintenance and operating procedures are in place to ascertain the proper functioning of structures, systems and components. No specific measures –other than the water tightness of the containment– exist for (threatening) external flooding situations. Once a year the gas leak tightness of the containment is tested, which is described in a procedure. Once every two years the containment is assessed visually.

3.2.3.2 Processes to ensure mobile equipment prepardnes

As there are no procedures to deal with flooding situations, there are also no procedures for using mobile equipment and supplies in case of a flooding.

3.2.3.3 Potential deviations from licensing basis

No deviations with respect to the licensing base have been established.

3.3 Evaluation of safety margins

3.3.1 Estimation of safety margin against flooding

The safety margins against flooding will be assessed by a step increase of the flooding level. The relevant flooding levels are given in Figure 3-6. These levels are based on the levels

safety (related) equipment becomes unavailable by flooding, and are as such not per definition equal to floor level.

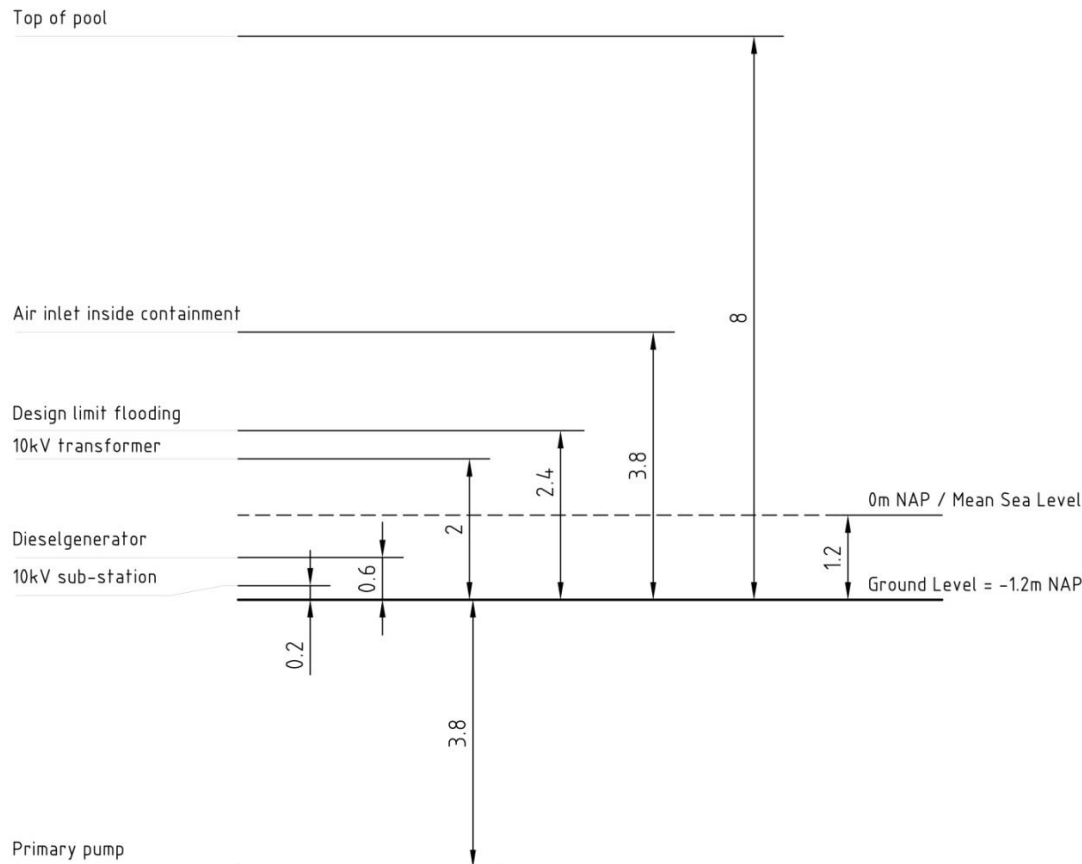

Figure 3-6: Heights of Safety relevant systems and structures.

The primary pump is the first system to fail. It is placed at 3.8m below ground level (-5m NAP). The pump is located in the basement below the reactor hall. This basement is not protected against water from outside the buildings and the pump itself is also not protected against flooding. This means that in case of flooding of the polder, the basement will almost immediately be flooded as well, even at very low flooding levels. This will result in a failure of the primary pump followed by a stop of the forced cooling flow. The following two things will happen:

1. The reactor scrams due to loss of primary cooling flow signals;
2. The suction head of the primary suction line underneath the core sinks and detaches itself from the core support plate. Convection cooling will start and secure cooling of the core.

The primary piping and heat exchanger will not be damaged as additional forces from the water on those components will be minimal. The amount of water in the pool is sufficient to cool the core for at least three years, Appendix D.

At 0.2m above ground level the 10kV substation feeding the 10kV/0.4kV transformers of the HOR becomes submerged, resulting in Loss of Off-site Power. The diesel generator will take over the supply of a limited number of systems like instrumentation. The cooling situation of the core does not change.

The next system to flood is the diesel generator, which floods at a level of approximately-0.6m NAP (0.6m above ground level). A station black out, as described in chapter 5, is the result: the Power to all systems is lost and instrumentation will follow in 1 hour after depletion of the batteries. No information on the condition of the core and the conditions inside containment is available. Convection cooling of the core is not impacted, so the core stays in safe shut down state. The amount of water in the pool is sufficient to provide cooling capacity for at least 3 years, Appendix D.

At a level of +0.8m NAP (2 m above ground level) a Station Black-Out (SBO) will definitely occur as the 10kV transformer, which could still be fed by the public grid, will start to be submerged, while the diesel generator is already submerged at a water level of -0.6m NAP.

At 2.4m above ground level (+1.2m NAP) the design limit of the containment building against external flooding is reached. A breach of containment may occur. If this happens water will enter the reactor hall that has no additional consequences as cooling is completely passive and the stability of the pool is not immediately threatened. The stability of the reactor hall could be temporarily threatened until the water inside and outside the building levels out.

If the reactor hall does not fail at its design limit the reactor hall will start flooding through the air inlet of the water seal at a height of 3.8m above ground level (+2.6m NAP). The consequences are the same as when a breach of containment occurs. The water will enter the reactor hall, but the containment function stays intact. The protection against overpressure in the reactor hall by the water seal fails because flooding of the inlet will result in higher "seal break pressure".

At 8m above ground level (+6.8 m NAP) the water reaches the top of the pool. This does not influence the cooling of the core. The cooling water however is now in contact with the outside of containment, and radioactive pollution of the environment is possible. As water is both on the outside and the inside of the reactor hall its containment stability is not immediately threatened. Still higher water levels do not change this situation, so fuel damage is no issue. In other words there is no cliff edge for flooding.

3.3.2 Measures to increase robustness of the plant against flooding

Of the three main safety functions only confinement is possibly jeopardized by flooding. Criticality and cooling are not threatened as shut down is assured by the reactor protection system and decay heat is absorbed by the pool.

Recent studies indicate that water heights that can be expected from floods will not exceed 2m above ground level. These levels are below the HOR design level (+2.4 m above ground level). Furthermore, in case of a possibly expected flooding it can be decided to shut down the reactor as a precaution (Good housekeeping) to ascertain that the reactor will be in safe shut down state before the primary pump is lost and, if needed, that the core is unloaded, as there will be time between the start of the flooding and the water reaching the HOR.

Robustness of the confinement function might be increased by modification of the water seal in such a way that flooding of the inlet will not result in higher "seal break pressure".

4 Extreme weather conditions

4.1 Design basis

This chapter describes the design basis of the HOR with respect to extreme weather conditions. The following weather conditions are taken into account:

- extreme high and low air temperatures;
- extremely high wind (including storm and tornado);
- wind missiles and hail;
- heavy rainfall;
- heavy snowfall;
- formation of ice;
- lightning;
- credible combinations of the conditions mentioned above.

It is noticed that all data with regard to weather conditions, that is presented in this chapter originate from the KNMI, the Royal Netherlands Meteorological Institute.

4.1.1 Reassessment of weather conditions used as design base

4.1.1.1 Verification of weather conditions used as designed base

Extreme high and low air temperatures

No minimum or maximum outside air temperature is defined as design base.

Reactor operation is affected by the outside temperature due to the effect on the temperature in the reactor building and the cooling capacity of the secondary cooling system (cooling towers). The temperature in the reactor building is controlled by control of the air inlet. A "frost pump" (CV pump) starts automatically (when switched in the frost position, which is default) when air temperature reaches 4°C. When the frost pump fails the air treatment is stopped automatically, followed by an AIS.

If temperature of the pool water becomes higher than 40°C, power of the reactor is reduced (AIS). If temperature of the water in the secondary cooling system is likely to become lower than 4 °C during shut down periods (e.g. weekends) , the secondary water is heated.

The diesel generator, including pipelines and storage tanks, are placed in a (heated) building. Low and high outside temperatures have no impact on the diesel generator operability.

Extremely high wind (including storm and tornado)

The original design basis of the reactor building was a wind speed of 45 m/s. In 1995, stability calculations of the containment of the HOR were performed by the engineering company Comprimo. Several loads were induced at the same time such as pressure of snow at the top (500 Pa), under pressure in the reactor building (1500 Pa), wind pressure in X-direction (2500 Pa) and external water pressure of 2.4 m. It was concluded that the containment has 17 % margin with respect to buckling. For wind speed therefore a design value of 63 m/s (which is based on a pressure of 2500 Pa) is assumed.

The ventilation stack is 60 m high and is located 30 m to the east of the reactor building (see Figure 1-2) and made of reinforced concrete. The wind load at which the ventilation stack falls down and consequently may hit the reactor building is unknown.

Wind missiles and hail

Wind missiles are projectiles propelled by extreme wind. A credible effect caused by projectiles could be Loss of Offsite Power due to damage to the power lines or the switchyard. This type of event is included in the Loss of Offsite Power sequences (see Chapter 5).

Hail is defined as precipitation in the form of spherical or irregular pellets of ice larger than 5 mm in diameter. Extreme hail can cause blockages in the cooling towers of the secondary cooling system. If the cooling capacity of this facility is not sufficient, safety systems will automatically reduce the reactor power.

It is possible that wind missiles could damage the reactor building but it is deemed unlikely that severe damage will occur which influences reactor operations.

Heavy rainfall

Extreme rainfall may induce additional force on building roofs. In case of raised edges, water can accumulate on top of the buildings if all drainage pipes are blocked.

Because the reactor building is dome-shaped, accumulation of rainwater is excluded. The roof of the pump building (secondary heat removal) has

only small raised edges, ~ 5 cm, on a small part of the roof. The largest part of the roof is occupied by the steep shaped cooling towers where accumulation cannot occur. The water on the flat part is removed by two downspouts. When the downspouts are blocked, water flows over the edges. The design of the roof is according to NEN 1055 (load capacity of 70 kg/m² corresponding to ~7 cm water), so water load will not lead to damage of the roof in case of accumulation.

The roof of the control room is provided with two internal downspouts. The edges of the roof are relative high ~ 30 cm. No overflow holes are made in the edges. The construction is designed according to NEN 3850 (load capacity of 75 kg/m^2 corresponding to ~ 8 cm water). In case of blockage of the downspouts water may accumulate on the roof till 30 cm. This may seriously damage the roof of the control room. Ultimate consequences are collapse of the roof of the control room causing damage to instrumentation and cabling. In the ultimate case, the control room will lose all connections to instrumentation resulting in the loss of control and monitoring functions. Due to loss of connections (power loss), safety systems like RSA, BIS and RIS are "activated" and fall into their fail safe positions. This means that the reactor is made subcritical and the pool and reactor building are isolated. So the three basic safety functions reactivity control, confinement and cooling are ensured.

Other buildings like the experiment hall and offices, are build according to NEN 6702 (new buildings) and NEN 1055 (old buildings) and provided with low edges (~ 5 cm) or higher edges with overflow holes, and downspouts. Eventual accumulation of rainwater does not lead to excessive forces on the roofs.

The RID area is not situated in a lower part compared to its surrounding area so no extra water from the surroundings will flow to the site area. For rainwater flowing to lower parts of the building via inclined roads/paths (for instance directly at the right side when coming through the main entrance), drain channels are provided. From these drains the water is pumped to channels outside the RID area. Failure of drain pumps may cause flooding in the basement of the reactor building in case of extreme rainfall. Flooding is covered in chapter 3.

Heavy snowfall

Heavy snowfall may lead to accumulation of snow on roofs, inducing a load on the civil structure. The RID buildings are designed according to different standards, due the differences in age and type. HOR,

The reactor building is designed for extreme situations. The design takes into account (calculations of Stork Comprimo 1995) a simultaneous occurrence of extreme winds, flooding, abnormal underpressure in the hall and a snow layer of 50 cm. The design value of 50 cm is therefore very conservative. Moreover, If it continues to snow for an extended period, no larger values of snow build up are to be expected for the reactor building due to its rounded shape.

The older buildings (and auxiliary buildings (e.g. pump building, and offices), isare designed according to the NEN standard 1055 to withstand the credible consequences of snowfall. Building standard NEN 1055 specifies a maximum snow load on flat roof tops of 70 kg/m^2 which corresponds to a level of fresh snow of approximately 70 cm.

The new offices and experiment hall are designed according to NEN 6702, which specifies a maximum snow load of 58 kg/m², which corresponds to a level of fresh snow of approximately 60 cm.

Formation of ice

The formation of ice on the Schie, a water channel at 800 m distance from the reactor building, does not influence the safe operation of the HOR (HOR is independent of the Schie).

Freezing of water in pipelines or water tanks in the pump building is prevented by heating elements inside the pump building and in the water collector on top of the building.

Freezing of other pipelines is prevented because water pipelines are underground. In the diesel building all pipelines are inside in the heated room. The pipe-basement is heated.

The inlet of the reactor building ventilation consists of a coarse grid in the building wall at ground level (auxiliary building) and leads to filter bags in the basement. Blockage of the filter bags by freezing (very improbable) gives a pressure difference signal in the control room. The ventilation system comprises a supply fan and an extractor fan keeping the containment pressure at about 100 Pa below atmospheric pressure (under pressure). When the inlet (coarse grid or filter bags) is significantly blocked, the supply air flow will decrease. As a result the pressure in the reactor building will decrease since the extraction fan is still running. At 200 Pa containment under pressure a low pressure control valve is opened to provide additional bypass inlet air. The ventilation system will stop automatically at a containment under pressure of 290 Pa. An AIS will follow. The fundamental safety functions are not threatened.

Lightning

Besides the standards for lightning protection to the reactor dome and adjacent buildings, storm is not explicitly included in the design basis. Lightning could affect the installation by lightning strikes, and may disrupt electronics due to strong accompanying electromagnetic pulses. If electromagnetic pulses strongly influence electronic equipment, safety systems are designed in such a way that the reactor is shut down. In case of failure of external power supply due to lightning, the reactor is scrammed. The scram is passive (control rods are gravity driven) so there is no need for internal or external power supply. Since the heat capacity of the pool is sufficient to absorb the residual heat from the core for a very long period (see chapter 5), no external cooling is required.

4.1.1.2 Postulation of proper specifications for extreme weather conditions

The data on extreme weather conditions are used of the KNMI weather stations Rotterdam Airport and Delft. The KNMI data have been used for the period between 1956 and the present.

Extreme high and low air temperatures

The maximum air temperature measured is 35.0 °C on 9 July 2010. The lowest air temperature measured is -17.4 °C on 7 January 1985. According to the Intergovernmental Panel on Climate Change (IPCC) an average temperature increase of 1.1 to 6.4 °C for the next century can be expected.

Extremely high wind (including storm and tornado)

For wind types, the following subdivision is used:

- Extreme wind speed (hourly average)
- Wind gusts (usually less than 20 seconds)
- Whirlwinds (unpredictable).

Extreme wind speed

The highest wind speed measured is 23.7 m/s on 25 January 1990. Research shows that the maximum wind speed (hourly average) that can be expected once every 10,000 years is approximately 35 m/s.

Wind gust

A wind gust is a sudden, brief increase in speed of the wind. The duration of a gust is usually less than 20 seconds. KNMI has determined that the maximum wind gust is roughly 1.5 times the maximum hourly average wind speed. At a wind speed of 35 m/s, this results in a maximum wind gust of 53 m/s once every 10,000 years on average. The highest wind gust measured is 41.7 m/s on 25 January 1990.

Whirlwind

The highest wind speed that was observed by a monitoring station due to a whirlwind in the Netherlands is 56 m/s. On average, each year about two whirlwinds cause some damage to the infrastructure somewhere in the Netherlands, over an area of one square kilometre. It is estimated that for a random location in the Netherlands, the risk of damage by a whirlwind is 10^{-5} per year.

Heavy rainfall

According to the statistics of the KNMI, in the Netherlands once in 10 years a rainfall of 50 to 62 mm will occur in some place. During the summer period it is possible that locally more

than 100 mm rain can fall. The largest recorded amount of rainfall in one day in Delft is 77 mm on 14 September 1998.

Heavy snowfall

On average, occasions of more than 20 cm of snowfall occur once every 10 years and more than 35 cm occurs once every 50 years.

Lightning

Lightning occurs on average 2 to 3 times per km²/year. Lightning strikes occur in the region of Delft approximately 28-30 days a year.

4.1.1.3 Assessment of the expected frequency of the design base conditions

In section 4.1.1.2 the expected frequencies of the design base conditions are given for the weather phenomena. It must be noticed that the design base conditions used in the fifties sometimes (they are unknown) differ from the extreme conditions used in 4.1.1.2. No major changes are to be expected in the return frequencies of the discussed phenomena. Most of the phenomena may be subject to climate change over a longer period.

4.1.1.4 Consideration of potential combination of weather conditions

High wind velocities combined with heavy snowfall may cause line galloping and lead to Loss of Offsite Power. However, this does not threaten the safety systems of the HOR.

The combination of high winds, extreme rainfall and lightning can be expected during a thunderstorm. Because the loads caused by these weather conditions are independent, the effect on the plant will not be reinforced.

4.1.1.5 Conclusion on the adequacy of protection against extreme weather conditions

The design basis wind velocity of 63 m/s gives some safety margin to the maximum highest wind velocity that was monitored in the Netherlands (56 m/s due to a whirlwind) or the maximum wind gust of 53 m/s which can be expected once every 10,000 years. The consequences of a wind speed of 56 m/s on the ventilation stack on the reactor building, are however unknown. The reactor building might be damaged by (concrete parts of) the ventilation stack in case of extreme wind. It is therefore recommended to investigate the allowable load on the ventilation stack.

For extreme rainfall the roof of the control room is not sufficiently protected. It is recommended to provide the roof of the control room with blocking proof rainwater drains, like overflow holes, to prevent accumulation of rainwater and exceedance of the roof design load.

4.2 The design is sufficient to protect the HOR against the other discussed phenomena. Evaluation of safety margins

4.2.1 Estimation of safety margin against extreme weather conditions

This paragraph contains an analysis of the potential impact of different extreme weather conditions on the safe operation of the HOR. The safety margin is defined as the difference between the allowable load (by design and/or by building standard) and the maximum load on buildings that can be expected as a result of the extreme weather conditions. Loads due to snowfall, rainfall and wind are derived from the weather conditions listed in the previous section. The remaining conditions (air temperature, formation of ice and lightning strike) cannot be translated into explicit loads and are only qualitatively discussed (i.e. not quantified).

Extreme high outside air temperature

Extreme high outside air temperatures will not threaten the fundamental safety functions of the HOR. When heat removal from the secondary system to the air in the environment is limited, reactor power is reduced.

In the ultimate case when no heat can be transported to the environment, the temperature of the water in the pool will slowly increase. Extreme high outside air temperatures will have only a slow direct impact on the temperature of the pool water. The heat capacity of the pool is sufficient to absorb the residual heat of the core for a very long period (see chapter 5).

Extreme low outside air temperature

The temperature in the reactor building is controlled by control of the air inlet. A "frost pump" starts (when switched in the frost position) when air temperature reaches 4°C.

If temperature of the water in the secondary cooling system is likely to become lower than 4 °C during shut down periods (e.g. weekends), the secondary water is heated.

The heat capacity of the pool is sufficient to absorb the residual heat of the core for a very long period (see chapter 5).

Extremely high wind (including storm and tornado)

The design basis wind velocity of the reactor building of 63 m/s gives some safety margin to the maximum highest wind velocity that was monitored in the Netherlands (56 m/s due to a whirlwind) or the maximum wind gust of 53 m/s which can be expected once every 10,000 years. The impact of a wind speed of 56 m/s on the ventilation stack is unknown.

Wind missiles and hail

The fundamental safety functions are not threatened by a loss of external power due to damages of missiles and hail. No cliff-edge is expected concerning damage of the buildings due to either wind missiles or hail.

Heavy rainfall

Because the reactor building is dome-shaped, accumulation of rainwater is excluded.

A small part of the roof of the pump building (secondary heat removal) has raised edges of ~5 cm, so water cannot accumulate above the design load. For the other buildings, small raised edges or overflow holes prevent water from accumulating above design load. For this, the safety margin is very high.

For the roof of the control room, raised edges are too high to prevent the roof from overloading in case the downspouts are blocked.

Heavy snowfall

The shape of the building does not allow for a large build-up of snow. Due to the design of the reactor building according to NEN 1055 and the shape of the building, a high safety margin can be applied.

For the small flat area of the pump building the margin for extreme snowfall is 35 cm. For the roof of the control room this margin is 40 cm and for the other buildings 25 cm.

Formation of ice

Formation of ice on the Schie is not relevant for the HOR.

Lightning

If the facility is subjected to lightning pulses with amplitudes above the designed levels, damage or false actuation of I&C channels may be initiated. This may lead to the shutdown of systems or a situation of Loss of Offsite Power (see chapter 5), which will lead to a reactor shut down. Cooling of the reactor is always ensured by the pool water.

4.2.2 Measures to increase robustness of the plant against extreme weather conditions.

It is recommended to investigate the allowable wind load on the ventilation stack. Depending on the outcome of this investigation the possible impact of the ventilation stack on the reactor building should be investigated.

It is recommended to provide the roof of the control room with blocking proof rainwater drains, like overflow holes, to prevent accumulation of rainwater and exceedance of the roof design load.

5 Loss of electrical power and loss of ultimate heat sink

5.1 Nuclear reactors

5.1.1 Loss of electrical power

In line with generic definitions, for the HOR the following plant states can be defined with regard to loss of electrical power:

1. Loss of off-site power (LOOP);
2. Loss of off-site power and station black out (LOOP-SBO).

The assumptions for the separate plant states are:

1. Loss of off-site power (LOOP)

This state is characterized by the unavailability of:

- supply by the on-site 10kV power station that is fed by the external grid.

2. Loss of off-site power and station black out (LOOP-SBO)

This state is characterized by the unavailability of:

- supply by the on-site 10kV power station that is fed by the external grid, plus;
- the diesel generator (also located on-site).

For both plant states it is initially assumed that uninterrupted power supply by batteries is available.

The Electrical Power System (EPS) contains three sections (see Appendix A).

From the safety point of view an emergency power supply is not necessary. When there is a power failure a RSA (Reactor Scram), a RIS (Reactor Hall Isolation) and a BIS (Pool Isolation) take place. However back-up power, supplied by a diesel generator, ensures that information, for monitoring, is available and the reactor hall is accessible.

5.1.1.1 Loss off-site power

5.1.1.1.1 Design provisions

Design provisions

The main power supply is obtained from an on-site 10 kV station, fed by the public grid, and is transported to the transformers which are located on the RID site. The transformers supply the main distribution box, which in turn supplies several distribution cabinets in the

institute. The electricity grid provides 400 V AC and 230 V AC. Figure 5.1 presents the basic diagram of the network. The parts fed by the diesel generator are in red; separate distributions boxes are numbered and grouped by main boxes.

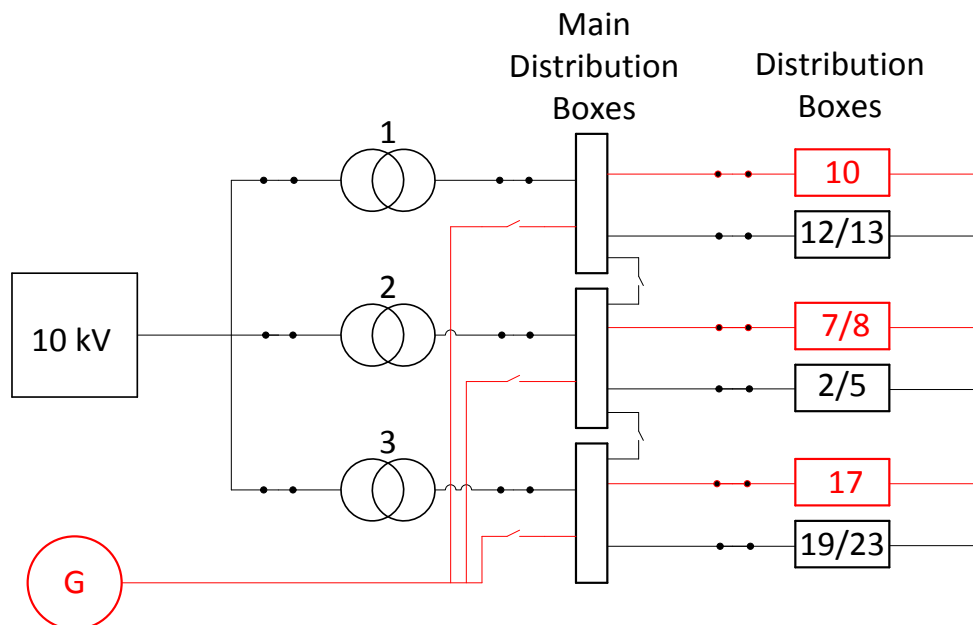

Figure 5-1: Diagram of the electrical power system

By design, there is no electrical power needed for the HOR to achieve and to remain a safe shut down state in case of loss of electrical power.

When there is a power failure a RSA (Reactor Scram), a RIS (Reactor Hall Isolation) and a BIS (Pool Isolation) take place. This means that the basic safety functions are met:

- Reactivity control

By automatic gravity driven insertion of the control rods when the electromagnetic coupling device de-energizes due to loss of power (RSA);

- Cooling

By dissipation of residual heat into the (isolated) pool by natural convection to the pool water (BIS);

- Confinement

By isolation through the "fail safe" isolation valves of

- the pool in case of leakage or failure of fuel elements;
- the reactor hall in case of increased airborne radioactivity.

Internal back-up provision

For the event of loss of off-site power, parts of the three sections are backed-up by the diesel generator; a/o systems such as personnel locks, emergency lighting and instrumentation. Uninterrupted power supply is assured to the last two systems by the uninterrupted power system (batteries).

For reasons of (re)operability, support systems, such as the frost prevention pump and the air-locks, are fed by the diesel generator. Appendix C lists those systems.

5.1.1.1.2 Autonomy of the on-site power sources

The autonomy period is defined as the time period that systems can provide their back-up function without on-site intervention or internal support e.g. switch over to other systems to supply water or diesel fuel in case the system under consideration runs out of stock. In this chapter only the autonomy period for electrical power supply is considered.

AC power

In case of loss of off-site power parts of the three sections of the electrical power system will be fed by the diesel generator in the generator building, see appendix A and B.

Fuel is supplied to the diesel generator by a day tank (volume 0.65 m³, minimum stock 0.5 m³), backed by a main tank of 1 m³ (minimum stock 0.5 m³). Consumption of the diesel generator is approx. 0.08 m³/hour at full load.

Every month operation of the diesel generator is tested and at the same time fuel stocks are checked and replenished. For this, an external supplier uses a standard check list. However, during the monthly checks fuel stocks are always far above the minimum stock of 0.5 m³. There is no procedure for refuelling during operation of the diesel generator, nor are arrangements made to assure supply of diesel fuel during emergencies.

DC power

An un-interruptible power supply system (UPS) with batteries is available. This provides un-interrupted power to the instrumentation and the emergency lighting for the short period at switch over from public grid to power supply by the diesel generator. Its design back-up time is 1 hour.

5.1.1.2 Loss off-site power and loss of the ordinary back-up AC power source

5.1.1.2.1 Design provisions

As indicated before, the three main safety functions do not depend on electrical power supply. Ultimately instrumentation for monitoring relies on the back-up batteries.

5.1.1.2.2 Battery capacity, duration and possibilities to recharge batteries

Design capacity of the batteries to feed instrumentation is 1 hour. Recharging is possible when external grid or diesel generator are available.

5.1.1.3 Loss off-site power, back-up AC power sources and permanently installed diverse back-up AC power sources

5.1.1.3.1 Battery capacity, duration and possibilities to recharge batteries

In the LOOP-SBO situation only batteries are available to provide during 1 hour power to instrumentation for monitoring and emergency lighting.

5.1.1.3.2 Actions foreseen to arrange exceptional AC power supply from transportable or dedicated off-site source

There are no provisions, means, procedures or alternative actions available or prepared to provide alternative off-site power supply. From a safety point of view, off-site power is not necessary for the reactor to remain in a safe shut down state.

5.1.1.3.3 Competence and time needed to make necessary electrical connections

Not applicable as no means are available.

5.1.1.3.4 Time available to provide AC power and to restore core cooling before fuel damage

Because cooling is provided passively by natural convection of pool water, the time available before fuel damage might start is the time until uncovering of the core starts. This will be discussed in paragraph 5.1.2.2.2.

5.1.1.4 Conclusions on the adequacy of protection against loss of electrical power

It is obvious that the HOR is designed to achieve and remain in a safe shut down state in case of loss of electrical power, without any interference from outside needed. With regard to the loss of electrical power, no additional measures are needed to maintain this state for a very long period. Without interference, this time is limited by the loss of cooling when pool water is not available anymore due to loss of coolant or evaporation and uncovering of the core starts. This issue is dealt with in paragraph 5.1.2.2.2.

5.1.1.5 Measures to increase robustness of the plant in case of loss of electrical power

Potential cliff-edge effects

For LOOP or LOOP-SBO situations, there are no cliff-edge effects identified.

However, monitoring of the plants' state through information provided by available instrumentation, in case of LOOP-SBO, will be possible only during the 1 hour battery capacity.

In case of LOOP this period will last 6 hours during diesel generator operation (given a minimum stock of 0.5 m³), while control activities from the control room are maintained. This period can be prolonged by refuelling the diesel generators during operation. A refuelling procedure for this situation is not available.

After 6 hours of diesel generator operation monitoring can be continued by one hour of battery capacity.

In case the control room is not available, monitoring of the plants' state is possible:

- through a monitoring desk in the Alarm Staff room next to the porters' lodge at the entrance of the RID building;
- by the alternative Alarm Staff room, located at the "Lucht- en Ruimtevaart" (L&R building) at the same LOOP conditions of the HOR, provided the L&R building has electrical power supplied.

Extension of monitoring means and especially monitoring time will improve monitoring of the reactor during LOOP and/or SBO conditions; the need for this should be elaborated.

Measures for improvement

Possible measures to improve the robustness of the plant, mainly meaning improvement of monitoring and control of the plant shut down state during LOOP or LOOP-SBO:

- Evaluate advantages of the introduction of a load reduction or load shedding programme in case diesel fuel saving is needed to extend operation time of the diesel generator when refuelling fails;
- Investigate the needs for monitoring the condition of the HOR in LOOP and/or SBO situations, the availability of the diesel generator and UPS related to their (time-limited) capacity to supply power and assure monitoring; increase of the battery capacity might be possible;
- Investigate possibilities to extend the monitoring capability in the alternate Alarm Staff Room (L&R building) by availability of measuring data and E-power;
- Improve means for diesel fuel transfer from the main tank to the day tank and provide a procedure or instruction for refuelling of both tanks during emergencies and long term of loss of off-site power.

5.1.2 Loss of the ultimate heat sink

ENSREG defines the ultimate heat sink (UHS) as "a medium to which the residual heat from the reactor is transferred. In some cases a plant has a primary UHS, such as the sea or a

river, supplemented by an alternate UHS, for example a lake, a water table or the atmosphere". Characteristic for those media is that they are almost infinite and in their bulk not affected by the heat discharge.

5.1.2.1 Plant cooling conditions

The following plant states for normal operation can be defined:

1. Normal power operation (weekly)

- a. Cooling is provided by the primary and secondary cooling system in case the reactor power exceeds 750 kW. The heat is discharged to the open air;
- b. The core is cooled by natural convection to the pool water for reactor power operation less than 750kW. Ultimately the

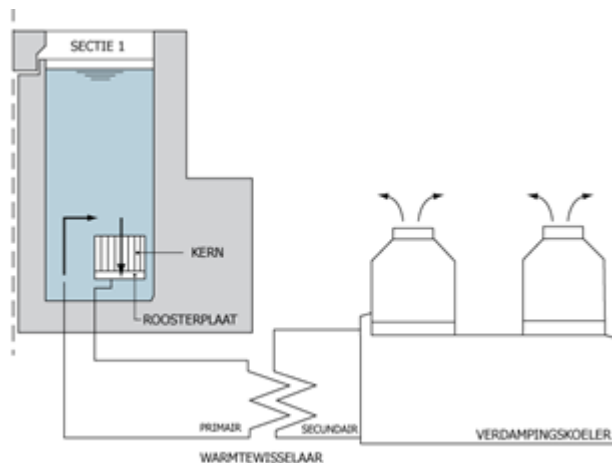

heat dissipated to and stored in the pool will be removed by the primary and secondary cooling system to the open air. (Although part of it will be discharged to the reactor hall atmosphere and removed by the ventilation system).

2. Normal shut down (after the weekly operation, RSA or during longer outage periods)

Residual heat is dissipated into the pool by natural convection to the pool water. When the pool water temperature is increased, heat is removed by the primary and secondary cooling system and discharged to the open air.

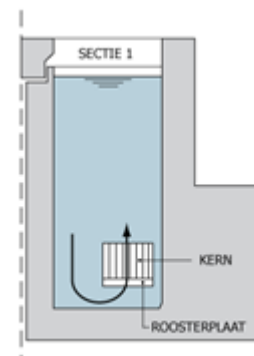

5.1.2.2 The ultimate heat sink and alternate ultimate heat sink

Based on the ENSREG definition and the defined (possible) plant states the ultimate heat sink of the HOR is provided by the open air. Because for both operational states ultimately the heat is dissipated to the open air; for power operation (more than 750kW) immediately and for low power operation (less than 750kW) and shut down after intermediate storage in the pool, by the combination of primary and secondary system. The cooling towers provide the last part of this cooling train.

An alternate ultimate heat sink, as it is indicated by ENSREG, does not exist at the RID site. However the pool, although ultimately not infinite, provides alternate cooling and can be considered as back up for the UHS. It will be dealt with under this denominator.

In case of loss of UHS, heat discharge from the core to the pool will cause a temperature increase of the pool. Then boiling starts. Ultimately this might result in uncovering of the core. If this happens two situations can be distinguished:

1. Partly uncovering of the core

Heat of that part of core that is still covered by water will be removed by convection to the pool water; the uncovered part will be cooled by conduction of heat to the covered, and cooled part of the core.

2. Complete uncovering of the core

When the water level drops below the bottom of the core, cooling will be provided by natural convection to the air of the reactor hall.

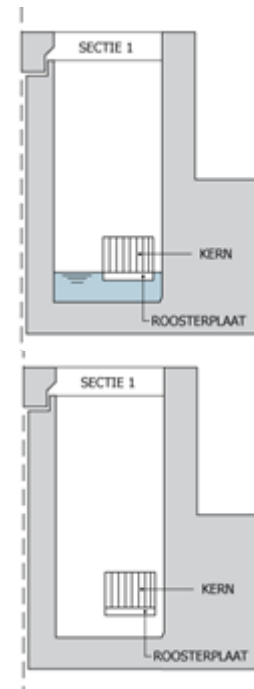

Appendix D presents the decay heat curve of the HOR after shut down at 3 MW including the heat load posed by the stored spent fuel elements. Based on this curve boil-off of the pool water is assessed. When only this boil-off is taken into account and heating up the pool to 100°C is neglected, it is concluded that it takes boiling of approx. 160 m³ of pool water to remove the decay heat for the first 3 years¹².

5.1.2.3 Design provisions to prevent the loss of the primary ultimate heat sink

Discharge of the residual heat of the reactor is provided by the combination of primary system and secondary system, after intermediate storage of this heat in the reactor pool.

¹² In the situation that section 1 and 2 are separated by the pool door and the core resides in section 1 (as is usual) only approx. 60 m³ is available for boil-off until uncovering of the core starts; this will take approx. 250 days: cooling of the spent fuel in section 2 (less decay heat (1,5 MW see appendix D), more water available (approx. 100 m³) will exceed those 3 years

Because the heat storage capacity of the pool is very large no additional means are needed so not provided for cooling of the pool water.

5.1.2.4 Loss of the primary ultimate heat sink

Loss of the ultimate heat sink (LUHS) for the HOR means that there will be no heat transfer to the open air via the secondary cooling system (no heat discharge by the cooling towers).

5.1.2.4.1 Availability of an alternate heat sink

It is assumed that for the HOR the pool will act as alternate ultimate heat sink, although it is ultimately not infinite. Cooling is provided by dissipation of the residual heat into the pool water. It is shown that the heat processing capacity of the pool (absorption by heating up and boil off) is sufficient to remove residual heat of the core for at least 3 years.

5.1.2.4.2 Possible time constraints for availability of alternate heat sink and possibilities to increase the available time

It is shown, see appendix D, that after 3 years the core is still covered by pool water, so heat is still dissipated.

5.1.2.5 Loss of the primary ultimate heat sink and the alternate heat sink

Loss of alternate heat sink (LAHS) means loss of the pool water. In this case there will be no ultimate heat sink operable because there are no means of heat transfer to this heat sink. So loss of the alternate heat sink means also loss of the ultimate heat sink.

In case of a postulated loss of alternate heat sink by loss of coolant, opposite to the slow procedure of heat-up and boil-off of the pool water, the water level may drop rapidly and (partly) uncovering of the core may start very soon, as presented in 5.1.2.2. It is not clear whether cooling of the core by water and/or air is sufficient to prevent fuel damage. Cooling possibilities for both situations have to be elaborated. First, when the core is partly covered by water and heat is removed by convection to and boil-off of water. Second, when the core is completely drained and cooling has to be performed by natural convection of (containment) air.

5.1.2.5.1 External actions foreseen to prevent fuel degradation

In case of loss of pool water, it is anticipated that water will be supplemented from the fire fighting system through a connection to the water storage tank of the pool. Means, connection pipe, are available; a procedure to perform this action is not available.

5.1.2.5.2 Time available to restore core cooling before fuel damage

It is indicated that in case of loss of pool water due to a break of the coolant line at the bottom of the pool, time until full uncovering of the core is 30 minutes. It is unclear whether connecting the fire fighting system and the water storage tank can be established in time and whether it is of sufficient capacity to replenish the pool up to core covering level. Alternatively, acceptance of draining of the pool and starting of cooling of the core by air is still under discussion and has to be elaborated.

5.1.2.6 Conclusions of the adequacy of protection against loss of ultimate heat sink

Because back-up of the UHS by the pool assures long term processing of the residual heat, the plant is adequate protected against this event.

5.1.2.7 Measures to increase robustness of the plant in case of loss of ultimate heat sink

Potential cliff-edge effects

For LUHS no cliff-edges are identified.

For LAHS the following potential cliff-edges can be identified:

- Failure to replenish pool water in time, leading to uncovering of the core ;
- Failure to cool a partly uncovered core by water or a complete uncovered core by air.

Measures for improvement

First of all the possibilities of loss of coolant, and thus the loss of the alternate heat sink, should be elaborated. In case this event can be excluded, e.g. by demonstration of the robustness of the double walled pipe-connections to the bottom of the pool and the robustness of the isolation valves, LAHS as an initiating event can be excluded. Enhancement of this robustness may be improved by introduction of additional leak detection or application of the leak-before-break principle.

Secondly, the situations for cooling of the core by water when partly covered by water, or cooling of the core by air when completely uncovered, should be elaborated. Results can vary from conclusions that cooling is always assured, that cooling is effective given certain pre-conditions (e.g. start after a certain decay time) or that cooling in this way is not effective. For the first situation no cliff-edges remain, for the intermediate situation additional measures might be needed as they will be necessary for the last situation.

For the last two situations, in case cooling by water and/or air might be insufficient, the following measures might provide possible improvement of the plants' robustness:

1. Because it is anticipated that supply by the fire fighting system may not completely compensate for loss of coolant (leakage and/or boil-off), a core spray that is independent of the loss rate, may be installed instead of direct supply to the pool via the water storage tank;
2. To prevent draining of the pool in case of pipe-break immediate underneath the connection to the pool, measures should be investigated to isolate this kind of leakages.

Additionally, isolation of the affected pool section by closing the pool door may be possible. For this situation either the core or the stored spent fuel or both have to be relocated to the unaffected pool section before the pool door will be closed. For core transfer from section 1 to section 2 and relocation from section 2 to section 1 an instruction exists; implementation of this instruction should be checked, see section 6.2.3.

Finally, procedures or instructions shall be provided to:

- replenish pool water by supply of water stored in several tanks inside RID;
- implement supply of water to the storage tank by the fire fighting system.

5.1.3 Loss of the primary ultimate heat sink, combined with station black out

Removal of residual heat of the core during LUHS is provided by the dissipation of that heat into the pool. This is completely independent of the electrical power supply. This means that loss of ultimate heat sink in combination with station black out is identical to the situation of loss of ultimate heat sink.

5.1.3.1 Time of autonomy of the site before loss of normal reactor core cooling conditions

This is identical to the situation of loss of ultimate heat sink, see 5.1.2.2.2.

5.1.3.2 External actions foreseen to prevent fuel degradation

Not applicable

5.1.3.3 Measures to increase robustness of the plant in case of loss of primary ultimate heat sink, combined with station black out

The combination of LUHS and SBO with respect to heat removal is identical to the LUHS situation. Therefore, compared to the LUHS situation, no additional measures to increase the robustness of the reactor have to be proposed.

5.2 Spent fuel storage pools

Spent fuel is stored in the pool. This means that decay heat generated by spent fuel is dissipated directly into the pool that is part of the primary system.

Therefore, methods and systems for heat removal of the spent fuel are the same as for core cooling.

5.2.1 Loss of electrical power

5.2.1.1 Measures to increase robustness of the plant in case of loss of electrical power

Measures are identical to those proposed for the reactor, see 5.1.1.5

5.2.2 Loss of the ultimate heat sink

5.2.2.1 Measures to increase robustness of the plant in case of loss of ultimate heat sink

As far as applicable, these measures are identical to those proposed for the LUHS situation of the reactor, see 5.1.2.5.

It is noticed that

1. Spray of spent fuel may not be necessary, because conditions are less severe than for uncovering of the core;
2. For the situation that section 2 of the pool is drained, this situation is in reverse of draining of section 1. For the situation that the core is in section 2 a procedure indicating that the core should be moved to section 1 and the pool door should be closed is at hand. Replacement of spent fuel is not indicated, this might not be necessary as cooling conditions are less severe. However, to anticipate this event, an instruction for replacement of the spent fuel for this situation should be added to this procedure. As indicated in 5.1.2.7 implementation of such an instruction should be checked, see also 6.2.3.

For both situations cooling by air might be sufficient; this should be part of the elaboration of the core cooling by air.

5.2.3 Loss of the primary ultimate heat sink, combined with station black out

5.2.3.1 Measures to increase robustness of the plant in case of loss of primary ultimate heat sink, combined with station black out

The same requirement as for LUHS, see 5.1.3.3, applies.

5.3 Supplementary consequences

ENSREG indicates that an assessment should be made for the situation that cliff-edges will occur and will result in loss of all means to mitigate the plant conditions dealt with in this report, so fuel damage or core degradation will result. The most severe events, in this context are the events that back-up of the LUHS (by pool water or air cooling) is not available or inadequate.

In these situations ultimately core cooling will be insufficient and core heat-up will start. Then core degradation cannot be excluded, so release of radioactivity into the containment will occur.

The timeframe of these events depends on the sequence that water depletion is caused by leakage and the speed that water is lost, so the time that uncovering of the core starts.

Succession of these events is included in severe accident management procedures.

6 Severe accidents management

6.1 Organization and arrangement of the licensee to manage accidents

6.1.1 Organization of the licensee to manage the accident

The Reactor Institute Delft (RID) is part of the Faculty of Applied Sciences of the Delft University of Technology. The RID operates one research reactor: the Hoger Onderwijs Reactor (HOR). According to the Dutch Nuclear act, the Executive Board of the university, being the licensee, is responsible for the HOR.

Being the Operator of the HOR, the RID is responsible for its safety. In general the RID operations are conducted conform the RID managements system (Kwaliteitsmanagementsysteem RID). Normal operating procedures and the Operating Limits and Conditions (OLCs) form the basis for safe operation. For accidents additional provisions are made. The RID is responsible for the organization of the on-site emergency response as well as for providing plant or site-status information to the local response team, authorities and regulator; this to enable organizations in charge to initiate possible regional or national emergency response.

The Emergency Response Organization (ERO) of RID as a whole (including supporting departments) is described in the RID Emergency Plan ("Bedrijfsnoodplan"). This RID Emergency plan describes how the RID organization will respond to an emergency situation. After an alarm or incident the first response is handled by the ERO or by the "Bedrijfshulpverleningsorganisatie" (BHVO). The RID Radiation Protection Department ("Stralingsbeschermingsdienst / SBD") takes part in of the ERO. In the first phase of an incident a Policy Team is formed. This policy team coordinates activities of the ERO, Radiation Protection Department, the local emergency services and authorities. Coordination within the ERO is arranged via the coordinating activity called the "motorkapoverleg". The complete ERO organization is shown in Figure 6-1. Note that the RID organization is referred to as IRI, the former name of the institute and that emergency classification will determine the involvement of local and regional emergency services and authorities.

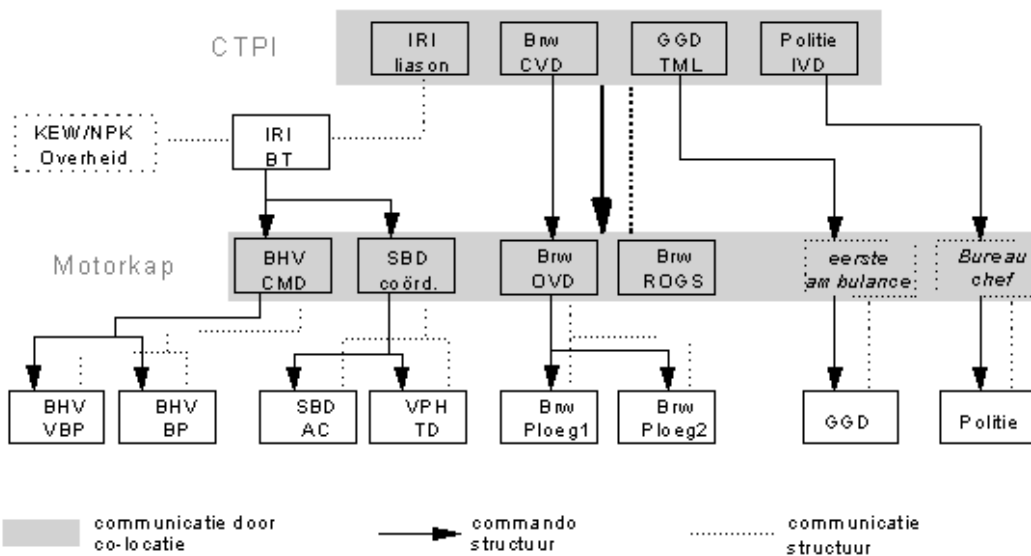

Figure 6-1: Complete Emergency Response Organization (ERO) from RID (former IRI)

A list of abbreviations of the organizations involved in the ERO is shown below.

AC	Emergency Centre TU Delft
BHV	Emergency Services
Brw	Fire brigade
BT	Policy Team RID TU Delft
CMD	Commander
CVD	Commander of Service
CTPI	Coordination Team Place of Incident
GGD	Public Health Service
OVD	Duty Officer
ROGS	Regional Officer Hazardous Substances
SBD	Radiation Protection Service RID TU Delft
TD	Technical Service RID TU Delft
VBP	Extended Base Package
VPH	Head Collecting Station
IVD	Inspector of Duty
IRI	Former RID
TML	Additional Medical Liaison

Whereas the RID emergency plan describes the Emergency Response *Organization* of the whole institute during an emergency situation, specifically for the HOR and its operations team a set of procedures and instructions is available. The emergency procedures of the HOR describe which instructions to follow during an emergency situation and its administrative settlement afterwards. The emergency instructions describe the technical actions that the operations team has to perform to bring and maintain the reactor into a safe shutdown state and to ensure cooling and confinement.

6.1.1.1 Staffing and shift management in normal operation

During normal operation from Monday until Friday the control room is permanently staffed with operator teams with a minimum of 2 persons in 3 daily shifts. During the weekend the reactor is kept in cold shut down condition and staff is available in emergency cases by means of consignment. An overview of the consignments is shown in Table 6-1.

Table 6-1: Consignees outside normal operation

Department	Consignee
Reactor Supervisor*	Staff member HOR-B or HOR-O
SBD Supervisor	Member of SBD
Weekend Supervisor	Head of concierge or replacement
Fire Supervisor	Chef Control Group HOR-B
TD Supervisor	Member of TD

*) only during Reactor Operation

The RID security lodge, where access to the RID buildings including the HOR is controlled, is permanently staffed by security personnel. This security lodge also houses the Central Alarm Control Room of the complete Delft University premises.

6.1.1.2 Plans for strengthening the site organization for accident management

The RID Emergency plan and the Regional Emergency Plan RID are evaluated and updated on a regular basis.

6.1.1.3 Measures taken to enable optimum intervention by personnel

The ERO is defined in the RID Emergency Plan, by which personnel is directed to perform emergency actions during emergency situations. Emergency actions depend on the scenario; two main scenarios are defined:

Scenario A: Emergency with possible radioactive release into the reactor building;

Scenario B: Emergency with a fire in the laboratory with possible release of radionuclides.

For a B scenario no additional measures are foreseen outside the RID premises other than the standard instructions to the Fire Brigade and Police. An A scenario could necessitate external measures.

The ERO has been tuned with the Regional Response Plan of Delft ("Rampenbestrijdingsplan") and the national crisis organization as defined in the National Plan for Nuclear Emergency Planning and Response (NPK, not specifically related to the HOR but to all nuclear facilities). The Emergency Response Plan of RID was established in a covenant between the Mayor of Delft and the Director of RID, and submitted to the Authorities (KFD).

The coordination via the RID Policy Team and RID Liaison with the (local) authorities is shown in Figure 6-1. Note that the RID organization is referred to as IRI, the former name of the institute. Regular meetings between local authorities and the RID are held in order to keep the Regional and RID emergency plans (i.e. "Rampenbestrijdingsplan") resp. "Bedrijfsnoodplan" synchronized. Improvement actions are initiated in these meetings. The emergency plans and organizations have been changed several times in order to cope with new developments in responsibilities and in the local response organizations. On-site training exercises are organized together with the Fire Brigade, Police and Ambulance-services.

The RID Emergency Plan describes how different parts of the ERO act in different emergency situations a/o.:

- First aid;
- Dealing with alarm signals (fire, radioactivity);
- Containment isolation and evacuation;
- Onsite evacuation;
- Monitoring of plant status and communication (internally and externally).

6.1.1.4 Use of off-site technical support for accident management

Off-site technical support is provided by regional facilities, such as fire brigades. The organization of off-site support is described in the aforementioned emergency plans. A RID liaison in the regional crisis organization will be responsible for coordination with external parties.

In case of an accident the RID site is accessible via the main entrance (gate West of the reactor site), see Figure 6-2. For RID the following response times are used for the emergency services:

- Fire brigade 8 minutes – After an alarm period of 3 minutes with no counter action on-site, the alarm is automatically forwarded to the fire brigade 'Haaglanden'. Their response time is 5 minutes;
- Police 5 minutes;
- Ambulance max. 15 minutes.

An additional entrance is available at the North side of the RID site. Access via this route is limited for large and heavy vehicles (e.g. Fire Trucks) because of tight corners and unstable ground.

The National Authorities can, according to agreements in the NPK, provide additional means through the RIVM¹³ and military services. A special team for 'dangerous goods' ("gevaarlijke stoffen team") is available on a national level. This team is located in The Hague and can be on site in 20 minutes. Among others, this team is equipped with 'HazMat' (hazardous material) suits and cleaning equipment for cleaning contaminated people.

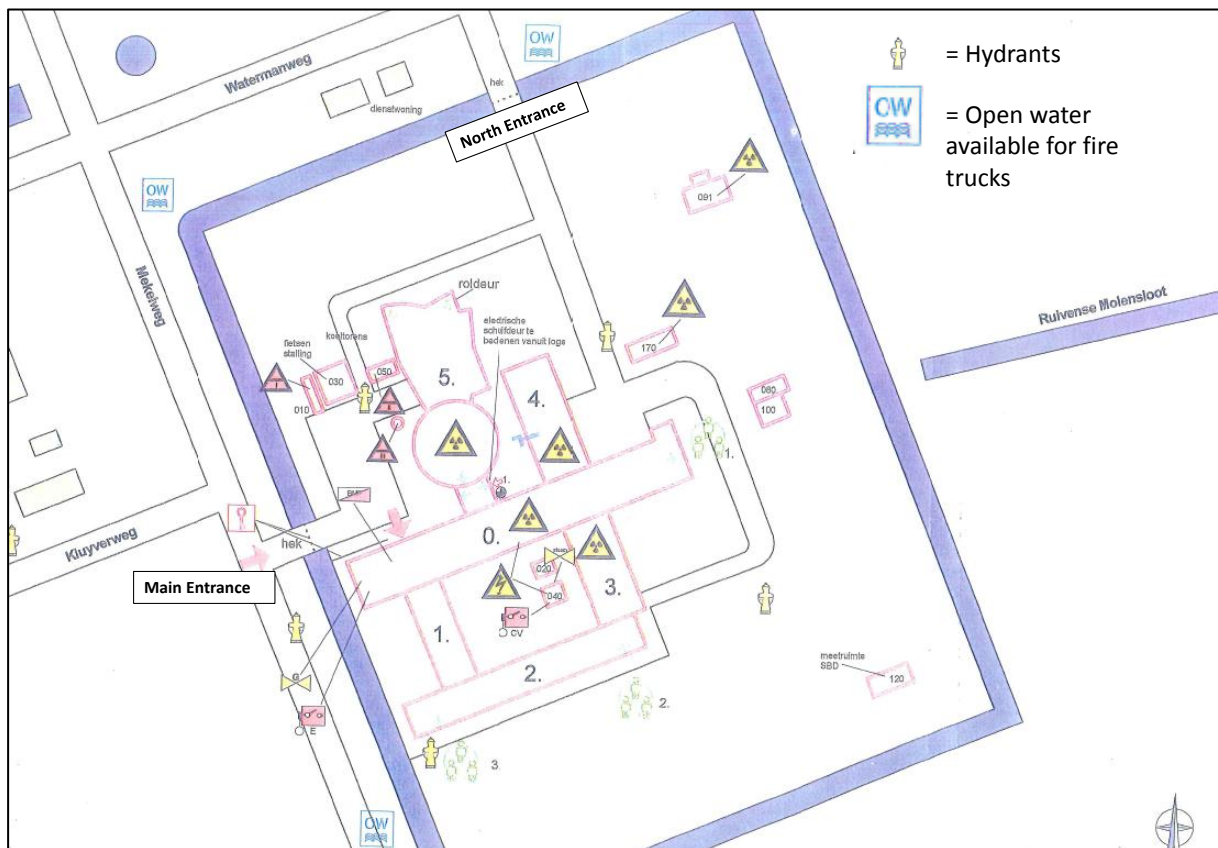

Figure 6-2: Map for emergency planning of Fire Fighters

¹³ Rijksinstituut voor volksgezondheid en milieu (Governmental Institute for Public Health and the Environment)

6.1.1.5 Procedures, training and exercises

The skills and emergency preparedness of the RID ERO is maintained by regular checks and training exercises. The alarm systems are tested on a periodic basis. The training and checkup program consists of the following actions:

- Members of the Policy Team (BT) and Radiation Protection Department (Stralingsbeschermingsdienst–SBD) exercise at least 4 times a year;
- Members of the ERO (BHV) exercise at least 10 times a year;
- The call-up signal of the ERO (BHV) is exercised at least 6 times a year;
- The building alarm procedure is exercised at least once a year by all attendees during the alarm test;
- The functioning of the building alarm signal is tested every month;
- The functioning of the Hall alarm / call-up signal is tested during every reactor check-out before starting up the reactor after the weekend;
- The functioning of the Fire Alarm system and the communication connection with the regional fire brigade is tested on a weekly basis.

All functional tests are recorded in a log book. The performance is evaluated with the RID Head of the Program for Safety and Health (H.PVM) and the ERO (BHVO) after every exercise. If necessary, updates of the RID Emergency Plan will be initiated.

The connection between the different plans and the HOR procedures is shown in Figure 6-3. The RID Emergency plan describes how the organization should respond in an emergency situation and takes care of the RID personnel. The HOR Emergency Procedures give guidelines to operator personnel how to respond in emergency situations. The instructions for operator personnel are detailed descriptions of how to handle emergency situations. RID is currently revising these procedures and instructions including the document structure in order to improve the transparency and user-friendliness.

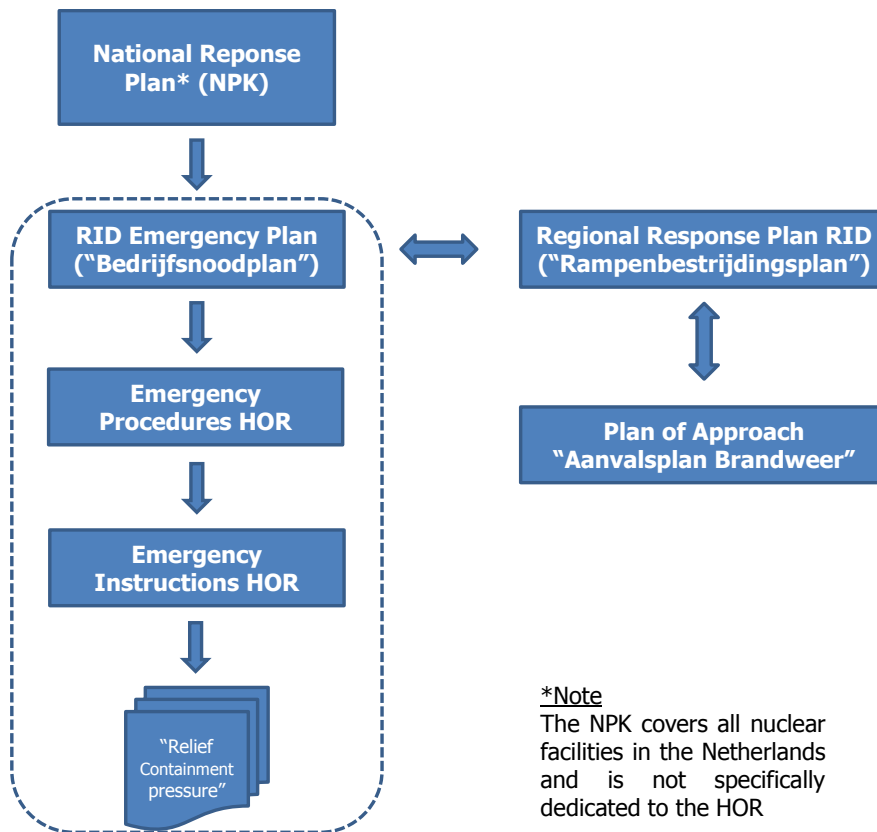

Figure 6-3: Connection between Emergency Plans for the HOR

6.1.2 Possibility to use existing equipment

6.1.2.1 Provisions to use mobile devices

No dedicated provisions for using mobile devices such as generators and pumps are foreseen because they are not deemed necessary for the HOR. The HOR is not depending on electrical power and active cooling for maintaining the basic safety functions (criticality, cooling and confinement). However, a standard package of equipment is available for the ERO: Self-Contained Breathing Apparatus (5 sets), Porto phones (7), First aid kits and Pagers. A small forklift truck and small lorries (from facility services) are available onsite for local transport and lifting of material. Standard mobile equipment can be provided by the local fire brigade such as pumping trucks, mobile pumps and mobile generators and lighting equipment.

6.1.2.2 Provisions for and management of supplies

For safe shut down of the reactor no external or emergency power sources are needed. For, e.g. monitoring and control functions as well as support systems, a diesel generator (280 kW) and UPS system are installed. The UPS is able to provide power to the reactor status monitoring for 1 hour. The maximum total diesel storage capacity for the diesel generator is 1.65 m³ (1 m³ storage tank and 0.65 m³ day tank.) The generator is checked-out monthly by

an external service provider. The day tank is filled when the level drops below 0.5 m³. The storage tank is also filled when the level drops below 0.5 m³. So the minimum present diesel storage is 1 m³ and provides generation capacity for 12.5 hours¹⁴ (diesel consumption at rated power is 0.08 m³/h). Note that there is no connection between the day and storage tank. Filling and level checking must be done manually. The procedures for maintenance and checking are arranged centrally via the FMVG (Facilities Management and Real Estate) of the Delft University and the FMVG has contracted this work to an external service provider.

Provision of food to RID staff is arranged via the central Catering Services. No specific provision in case of emergency is arranged.

6.1.2.3 Management of radioactive releases, provisions to limit them

The monitoring and supervision of possible radioactive releases rests at the radiation protection service of the RID. They are provided with measuring data via the continuous on-site monitoring system. This monitoring system called Central Registration System (CRS) consists of 20 channels for measuring the following quantities:

- Radio-activity in (ventilation) air;
- Radio-activity in disposal water in the collection tanks;
- Exposure rate;
- Wind speed and wind direction.

The containment provides limited shielding and isolation of possible radioactive releases. The procedures for Containment Isolation and Pool Isolation in order to prevent releases into the environment are laid down in the RID Emergency Instructions. In order to maintain the containment integrity after isolation (e.g. during changes in outside atmospheric weather conditions), the pressure shall be kept below the design pressure. The design pressure of the containment is 10 kPa (over pressure) and 1 kPa under pressure. The Water Seal is designed to 'break' at 10 kPa overpressure resp. 1 kPa under pressure. As described in the Plan of Approach and the RID procedure "AFLATEN HALLUCHT BIJ CALAMITEIT", pressure shall be relieved via the gas meter bypass and subsequently the ventilation stack when the containment overpressure exceeds 1 kPa (10 cm water column) respectively 'approaches 10 kPa'. The containment leak rate is tested on a regular basis.

¹⁴ Opposite to the assumptions of chapters 1 and 5 that only the minimum stock of the day tank is available, for SAM it is accepted to suppose refueling of the day tank by the minimum stock of the storage tank

At containment over pressures above 10 kPa uncontrolled pressure relief will take place via the water seal. The containment has been tested at a pressure test of 11 kPa after finishing construction. So there is margin with respect to the design pressure.

Since the RID has an 'open pool' type reactor with low or atmospheric pressure, no containment pressure rise is to be expected as a result of a LOCA. In case of Loss of Ultimate Heat Sink (LUHS) the pool temperature could increase slowly, ultimately leading to a situation of long term water evaporation of the pool (see Section 5). Since the heat input is relatively low compared to the containment size and heat transfer surface, no over pressure is expected in this situation.

6.1.2.4 Communication and information systems

Within the RID emergency plan a number of communication and information systems are defined which are tested and trained on a regular basis, comprising:

- Building communication system;
- Intercom RID Radiation Protection Service;
- Intercom HOR;
- Pager Installation including Semaphones / Buzzers;
- Porto phones;
- GSMs;
- Internal and external phone connections;
- Direct communication line between Alarm Centre-TUD and the Regional Alarm Centre (Haaglanden).

In addition, the RID has an alternative Alarm Staff Room in the Aerospace Technology building (L&R). From this room information on the status of the reactor and the onsite radiation monitoring system is available online (live).

The external communication with Local Authorities depends on the type of emergency scenario as laid down in the RID Emergency Plan:

- Scenario A: Emergency with possible radioactive release into the containment building;
- Scenario B: Emergency with a fire in the laboratory with possible release of radionuclides;

6.1.3 Evaluation of factors that may impede accident management and respective contingencies

6.1.3.1 Extensive destruction of infrastructure or flooding around the installation that hinders access to the site

The RID can be reached via several main roads and a large number of local roads. In case of blockage of the main roads A13 and N470, alternative routes are possible, for instance via the A4 or N468 in the west.

When the main gate on the West side is blocked, site access is available via the smaller North entrance. However, this entrance has limited capacity in terms of heavy load and large vehicles.

The RID Alarm Staff Room at the Faculty of Aerospace Technology is located at elevated level (8th floor), hence this facility will still be available in case of flooding of the site.

It has to be noted that due to the low level of residual heat of the reactor after shut down, the dependence on local infrastructure for electrical power and active water cooling is very limited. There are no additional provisions for access to the site in case of extensive damage of infrastructure.

6.1.3.2 Loss of communications facilities / systems

Normally no communication is needed to maintain safe shut down conditions. However, communication is essential when there is an emergency that requires intervention of auxiliary services such as the fire brigade or authorities. Communication in such cases is arranged via the RID emergency plan. A list of available communication tools is shown in section 6.1.2.4. No specific loss of communication scenario has been evaluated.

6.1.3.3 Impairment of work performance due to high local dose rates, radioactive contamination and destruction of some facilities on site

In case of a radioactive release into the containment, the containment will be evacuated. For the 'enveloping accident' as described in the Safety Report, no large scale off-site evacuation is needed. Depending on the severity of the release the evacuation is mainly limited to onsite evacuation. Work in and near the containment will be impaired. In the event of an airplane crash directly into the containment building the site will be evacuated up to several hundred meters from the reactor building. In first place action will be initiated according to an A-scenario in the RID and Regional Emergency Plan.

6.1.3.4 Impact on the accessibility and habitability of the main and secondary control rooms, measures to be taken to avoid or manage this situation

Normally no operator actions are needed to maintain safe shut down conditions. The main control room is attached to the containment. There is no additional shielding between the control room and the containment, besides the containment and control room structure itself. In case of a significant radioactive release into the containment, the control room needs to be evacuated according to dedicated instructions. The RID emergency plan will initiate evacuation and the HOR Emergency Instructions give guidance to the operators how to act in this situation. The Alarm Staff Room and alternative Alarm Staff Room are provided with essential monitoring data from the reactor (status information) and are therefore considered 'secondary control rooms'.

In Table 6-2 a general overview is given of the availability of the Main Control Room, the Alarm Staff Room inside RID (0.K0.200) and the alternative Alarm Staff Room in TUD Aerospace Technology on the 8th floor in case of different external hazards.

Table 6-2: Impairment of rooms or buildings due to external hazards

Room	External Hazard							
	Flooding	Earthquake	Fire at HOR/RID	Extreme Weather	Aircraft Crash HOR/RID	Explosion	RA Release >A-B Scenario	
Main Control Room	+	+*	-	+*	-	R	-	
RID ERO Room	-/+	+*	-	+*	-	R	-	
ERO / Monitoring Room: TUD Aero Tech. 8 th floor	+	+*	+	+*	+	R	+	

"-" = Vulnerable, "+" = Available, "R" = Redundant, * = based on existing building & construction codes, no specific analyses available.

In case of a significant dose rate on the RID premises due to an event in the HOR, the alternative Alarm Staff Room is still taken to be available. No accident management activities under these conditions are foreseen by control room operators. The RID Alarm Staff Room

(0.K0.200) will be available in case of flooding levels below 0.26m NAP. In case of an explosion with local effects it is expected that one of the rooms will be available; hence their qualification 'Redundant'. Since the seismic activity in this area is low, no seismic design analyses have been performed in the construction phase. Based on the existing building regulations and the low seismic activity it is expected that the Control Room and Alarm Staff Rooms will stay available in case of a seismic event. Extreme weather (e.g. heavy storms, heavy rain) are taken to be covered by the existing building & construction codes, and therefore assumed to be available as well.

It is concluded that in case of external hazards at least one control room is available.

6.1.3.5 Impact of the different premises used by the crisis teams or for which access would be necessary for management of the accident

The premises used by crisis teams are shown in Table 6-2. No specific accident management activities are foreseen to maintain the basic safety functions because of the relatively robust design of the HOR. As explained in paragraph 6.1.3.1 the RID site is accessible from different directions (North and West). At least one of the Alarm Staff Rooms will remain available.

6.1.3.6 Feasibility and effectiveness of accident management measures under the conditions of external hazards (earthquakes, floods)

No specific accident management procedures are foreseen. Possible activities to restore power for monitoring and control functions may be impaired due to flooding or earthquake related damage. Potential efforts to refill the Reactor Pool¹⁵ after an extreme event may be impaired by infrastructural damage (i.e. fire fighters with pumping trucks are not available, while water from tapping points may be available still). In case of flooding, the reactor will be shut down well in advance since the flooding scenario's for RID are slow (see Section 3 Flooding). No specific safety issue is expected in that situation.

6.1.3.7 Unavailability of power supply

The HOR is not depending on electrical power for maintaining the basic safety functions (Cooling, Confinement and Criticality). However, if the diesel generator and/or UPS are not available, there is no status information of the reactor available. In case of Loss of offsite power, AC power from the Diesel generator is available in the Alarm Staff Room for

¹⁵ Refilling of the reactor pool may not be necessary, depending on the outcome of a study on the cool ability of the fuel, see Chapter 5.

monitoring and lighting. The alternative Alarm Staff Room has no power connection with the diesel generator. Lighting and status information will not be available in this room after loss of off-site power of this room. In case of loss of off-site power, the radiation protection department (SBD) can use the handheld radiation monitors from their standard equipment package.

6.1.3.8 Potential failure of instrumentation

The flooding and earthquake resistance of all instrumentation is not known. The most likely failure mechanism for the instrumentation will be the loss of power supply (see section 6.1.3.7).

6.1.3.9 Potential effects from the other neighbouring installations at site

There are no other units onsite. A fire or small explosion in a neighboring building with laboratories may limit accessibility. However, since the HOR is not depending on accessibility or power for maintaining safe shutdown conditions, this scenario itself will not compromise reactor safety.

6.1.4 Conclusion of the adequacy of organizational issues for accident management

The RID emergency response organization (ERO) is described in the RID emergency plan and covers a wide range of emergency scenario's by giving directions to who is responsible for the issues involved; first aid, fire, radiological and technological aspects. Proper actions shall be taken by these responsible persons. If needed, additional assistance will be provided by local emergency services. This is trained and plans are updated on a regular basis, as laid down in the RID emergency plan. The larger part of the actions are related to first aid, firefighting, evacuation and monitoring. On this basis it can be concluded that the organizational issues for accident management are adequate.

However, no provisions are made for possible actions to restore safety functions or mitigate consequences as a result of an extreme event, possibly with high dose rates. On the other hand, the HOR proves to be very robust.

6.1.5 Measures to enhance accident management capabilities

- Revise and clarify organizational chart in the RID Emergency Plan (e.g. replace IRI by RID);
- Make an inventory of equipment of Fire Brigade Haaglanden and adjust plans for possible emergency provisions (e.g. additional power connection for monitoring functions, water connection for refilling reactor pool);
- Both procedures for containment pressure relief in "Bedrijfsnoodprocedures" and the "Aanvalsplan" may be checked on consistency (1 kPa versus approaching 10 kPa) and

effectiveness. Add the instruction that consultation of the Radiation Protection Department (SBD) is needed about internal recirculation over the filters in order to reduce release fractions before pressure relief;

- Investigate the need and possibility to have an additional procedure for fast and continuous provision of diesel to the diesel generator tanks in case of extended loss of off-site power. This is now arranged via a general contract of FMVG (Facility Services) on a monthly basis;
- Check the preparedness of local emergency services (e.g. Ambulance personnel) for radiological events.

6.2 Accident management measures in place at the loss of core cooling function

The reactor pool does not need active cooling in shutdown conditions because of the large heat capacity of the reactor pool compared to the decay heat of the core. In case of loss or depletion of pool water, actions may be necessary to keep the reactor core covered and cooled by water. It has to be remarked that (partial) uncovering of the core leads to high local dose rates but partly cooling by water and air may provide sufficient cooling to keep the fuel from degradation (see chapter 5).

6.2.1 Before occurrence of fuel damage

The RID emergency instructions provide instructions in case of a Reactor Pool LOCA¹⁶. The reactor pool is divided into 2 sections which can be isolated by a pool section door. Operation of the HOR is only possible with the pool section door in open position. In case of a LOCA in one of the two sections, the core can be transferred to the intact section and isolated by closing the pool door, provided that there is enough time to perform this action (depending on the LOCA size). The spent fuel is not mentioned in these instructions because this fuel is taken to be "decayed and cooled" enough to be sufficiently cooled by air. It is recommended to analyze this ability to cool further (see recommendation chapter 5). It must be noted that the polar crane is not connected to the Diesel generator. The crane cannot be credited for accident management inside the containment after loss of off-site power. The emergency instruction for relocating the core is assumed to be performed by manual actions. For spent fuel relocation this situation is to be analyzed.

¹⁶ A scenario with a water 'leak' is normally referred to as a Loss of Coolant Accident (LOCA)

There is a possibility to fill the Reactor Pool via a connection on the water storage tank with a fire fighting connection. Hardware provisions are available and it is foreseen to develop a procedure.

In addition, 4 water hydrants are available onsite to provide water for fire fighting or cooling (see Figure 6-2). The canal around the HOR site at 1 km distance provides an additional water source for mobile (fire) pumps. The canal is connected to the Schie pumping station via several canals. Therefore the supply of water can be maintained for a long period. For the availability of fire pumps the RID depends on the fire brigade, since no equipment is available onsite.

6.2.2 After occurrence of fuel damage

In case of fuel damage, no specific procedures are available except for the approach according to an A or B scenario. This approach covers a/o. evacuation, fire fighting and communication according to the RID emergency plan.

External water connections in combination with procedures should enhance the capability of restoring core cooling / mitigate the consequences in case of a LOCA.

6.2.3 Measures to increase the accident management in case of loss of core cooling function

- It is foreseen to develop a procedure for refilling the water storage tank for adding water to the pool in case of a low level. Training and testing should be defined in this procedure as well;
- For the relocation of the core to the other pool section in case of loss of pool water, the handling time and dependence on tools or equipment should be evaluated by performing a training exercise of the existing emergency instruction. The required time will determine the leak rate that can be handled. The identified tools, dependencies (e.g. E-power for polar crane for spent fuel relocation) and expected dose rates will make it clear in what situations relocation is an option;
- The instruction on core relocation in case of a leak in pool section 2 should be complemented by guidance on the handling of spent fuel (depending on their ability to cool in air without degradation, see also recommendation Chapter 5).

6.3 Maintaining containment integrity after fuel damage in the reactor core

6.3.1 Elimination of fuel damage / meltdown in high pressure

The HOR is an open pool reactor which operates under atmospheric pressure. Hence, high pressure core melt is excluded on physical grounds.

6.3.2 Management of hydrogen risks inside the containment

Hydrogen production by oxidation of the zirconium fuel cladding at high temperature is excluded for the HOR since the HOR has fuel with Aluminium cladding.

6.3.3 Prevention of overpressure of the containment

Overpressure of the containment may lead to loss of the containment. This should be prevented by all means since it is the last of the four barriers (fuel matrix, fuel cladding, primary circuit and containment) to prevent possible radioactive release to the environment.

6.3.3.1 Design provisions

The integrity of the containment of the HOR is safeguarded by the passive water seal that will relief pressure above a pressure difference of 10 kPa or under pressure of 1 kPa between the inside of the containment and the outside. After pressure relief the confinement function of the containment is limited since there is an opening to the environment via the open water seal.

An internal explosion is not expected because of the absence of a combustible fuel source and/or pressurized (steam) systems. The water seal is therefore taken to have sufficient capacity to maintain the containment pressure below 11 kPa, which is the containment test pressure.

In the event of rising containment pressure, the pressure can be relieved via the "gasmeter" bypass or alternatively by a manual operated valve from the control room. The latter will induce an uncontrolled release into the control room and is therefore not a preferred solution.

6.3.3.2 Operational and organizational provisions

The water seal function is preserved by a procedure for controlled pressure relief of the containment via the "gas meter" bypass. The existing procedure for refilling the water seal should be checked for applicability in case of an unfortunate "break" of the seal as to restore the confinement function.

6.3.4 Prevention of re-critically

6.3.4.1 Design provisions

If the reactor power deviates more than the permissible deviation as laid down in the OLCs the control rods will automatically be inserted by the Reactor Protection System. Large deviations or loss of instrumentation will initiate a reactor scram. Re-criticality is prevented by means of a large shutdown margin in negative reactivity.

6.3.4.2 Operational provisions

During the check-out before the reactor start-up each Monday and the measurements done during the refuelling process, the core configuration is checked against the restrictions of the OLCs (VTS). The OLCs restrict storage areas in the vicinity of the core. OLC also does not permit transport of mobile racks in case they are loaded with spent fuel.

There are no additional means to prevent re-criticality of the core.

6.3.5 Prevention of base mat melt through

The reactor is an open pool type. Uncovering of the core by evaporation of pool water is highly unlikely considering the large water quantity that provides decay heat removal capacity for a long period (>3 year). Moreover, the core has a limited inventory and the pool has a metal liner. The pool floor is made of concrete with a thickness of more than 1.5 meter. As a second barrier a pipe basement with a concrete floor is situated below the core in the pool. Basemat melt through is limited by the heat transfer of the corium to the concrete. Since the core inventory is limited compared to the large thickness of the pool floor, basemat melt through is expected to be excluded.

6.3.6 Need for and supply of electrical AC and DC power and compressed air to equipment used for protecting containment integrity

The HOR does not need AC power supply for maintaining safe shut down conditions and / or preserving the containment integrity. The water seal is a passive over/under pressure protection system. The containment isolation valves are closed by compressed air, stored in an accumulator. To open the valves from the control room, electricity is needed. The valves can be operated manually on location. A diesel generator is available to provide AC power to essential parts of the installation (e.g. instrumentation and monitoring, containment locks, and fire alarm system). In addition essential parts of the monitoring system are powered by an UPS.

The containment ventilation system with absolute filters is not connected to the diesel generator. This system is not necessary for maintaining the containment integrity but may be used to reduce the concentration of airborne radio-active material.

6.3.7 Measuring and control instrumentation needed for protecting containment integrity

The instrumentation that is used to provide the confinement function in a wide sense is all instrumentation that provides status information of the integrity and cooling of the core (dose rates, pool water level). In addition the radioactivity of the containment ventilation system is monitored in order to initiate containment isolation.

6.3.8 Conclusion on the adequacy of severe accident management systems for protection of containment integrity

The loads on the containment are relatively low due to the low power density and the absence of pressurised (steam) systems and combustible sources. The water seal and the gas meter bypass are considered effective means to protect the containment integrity and with that the confinement function.

6.3.9 Measures to enhance capability to maintain containment integrity after occurrence of severe fuel damage

The existing procedure for refilling the water seal should be checked for applicability in case of an unfortunate "break" of the seal as to restore the confinement function. If practically achievable, connect the containment ventilation system to the Diesel generator in order to maintain filtering capabilities after loss of off-site power.

6.4 Accident management measures to restrict radioactive releases

Confinement of radioactivity is preserved by:

- Confinement barrier approach: Fuel matrix, Fuel Cladding, Primary system, Containment;
- Control and filtering of pool water;
- Control and filtering of (radioactive) airborne material at inlet and outlet of the ventilation system;
- Isolating the reactor hall in case the concentration of radioactive material exceeds discharge limits by closing the isolation valves of the ventilation system;
- Possibility of internal circulation and filtering of the air in case isolation is applied.

6.4.1 Radioactive releases after loss of containment integrity

During normal shut down conditions no radioactive releases are expected into the containment. Even the truck transport door can be opened under the conditions as laid down in the OLC.

After loss of containment integrity the regular ventilation and filtering systems can still be used to limit the releases. In Chapter 7 the scenario for Airplane Crash is described where the containment integrity could be lost.

6.4.2 Accident management after uncovering of the top of fuel in the fuel pool

6.4.2.1 Hydrogen management

No Hydrogen management activities are foreseen since no hydrogen production is expected within the HOR.

6.4.2.2 Providing adequate shielding against radiation

The reactor hall will be evacuated and a Containment Isolation will be initiated before or during uncovering of the core because of alarm signals and procedures. When the core is uncovered the pool structure will provide shielding. 8 hours after shut down of the reactor the dose rate at the edge of the pool during uncovering of the core will be approximately 100 Sv/h. The dose rate at the reactor hall floor is expected to be in average 4 decades lower, i.e. 10 mSv/h as indicated in the Veiligheidsrapport HOR (safety report). Since this is an average value and radioactive aerosols may be present, possible accident management activities inside the containment are expected to be performed under severe conditions.

6.4.2.3 Restricting releases after severe damage of spent fuel in the fuel storage pools

This action is equal to restricting releases after fuel damage in the core since spent fuel and core are both located in the Reactor Pool.

6.4.2.4 Instrumentation needed to monitor the spent fuel state and to manage the accident

Equal to the core monitoring systems.

6.4.2.5 Availability and habitability of the control room

Equal to the situation of high radiation dose rate inside the containment as described in section 6.1.2.4.

6.4.3 Conclusion of the adequacy of measures to restrict the radioactive releases

The restriction of radioactive releases is limited to the design provisions of the containment. The RID emergency plan prescribes evacuation measures in case of radioactive releases. These are considered to be sufficient for the HOR. The provisions for uncovering of fuel and possible restriction of releases outside the containment are to be analysed further (see also recommendation Chapter 7).

6.4.4 Measures to enhance capability to restrict radioactive releases

- An evaluation whether the current plans give sufficient guidance in the extreme event of uncovering of the fuel.

7 Other extreme hazards

The following extreme events were identified for this analysis:

Explosion and fire related hazards:

- internal explosion;
- external explosion;
- internal fire;
- external fire;
- airplane crash;
- toxic gases.

Electrical related issues:

- large grid disturbance;
- failure of systems by introducing computer malware.

Water related issues:

- internal flooding;
- blockage of cooling water inlet.

The following information is elaborated for each of these hazards:

- General description of the event;
- Description of how the event could lead to consequences for the safety systems;
- Elaboration on these consequences regarding the generic safety functions.

7.1 Internal explosion

7.1.1 General description of the event

Internal explosions are defined as those explosions that originate from plant systems and plant storages. To protect safety relevant systems against the impact of internal explosions, the following measures are included in the design to prevent occurrence of internal explosion and to reduce their impact:

- Application (as far as possible) of inflammable gases and liquids instead of more obvious but combustible ones;
- Reduction of number and volume of explosive materials;
- Limitation of the releases of explosive materials in case of disturbances;
- Subjection of the storage of explosive materials to special precautions;
- Monitoring of risk areas combined with automatic safety measures;

- Ventilation of risk areas.

In the reactor containment building, gas cylinders are stored on the ground level, first platform and second platform and contain only inert or noble gases. The gas cylinders contain:

1. Argon;
2. Helium;
3. Nitrogen.

Release of the gas in the reactor containment building can therefore not lead to an explosive mixture. In principle, although unlikely, it is possible for a gas cylinder to rupture. The gas content will then be released in a short time into the containment area. The total number of stored gas cylinders in the reactor building at the mentioned floor levels is limited to about 5.

For the other buildings, gas cylinders are stored outside the buildings in special storage places which meet international standards. Most gasses are noble or inert gases. The few present explosive gasses are nearly all mixed e.g. with 90% Argon. Only under strict conditions (special housings and locations) very limited amounts (liters) of explosive gasses are allowed to be used in a lab.

7.1.2 Potential consequences for the safety systems

In case of rupture of a gas cylinder an extra volume of gas will be released in the reactor containment building (maximum content of gas cylinders is 50 litres at 200 bars). In comparison to the total volume of the reactor hall (20000 m³), the extra volume is very small (0.05 %). The containment is able to deal with this sudden extra gas volume within the reactor building. Over pressure in the containment is prevented by a water seal. Although small damages to equipment could occur, the resulting forces of a gas cylinder rupture are too little to cause damage the pool.

To minimize the risk of gas cylinder rupture, pressurized gas cylinders as mentioned above are to be removed from the reactor hall as much as possible.

Due to the limited amount of explosive gasses in/outside the other buildings of the RID, no significant damage to buildings is expected in case of an occurring explosion. The fundamental safety functions of the HOR are not threatened.

7.2 External explosion

7.2.1 General description of the event

Explosion pressure waves may generally result from accidents in nearby facilities or means of transportation. The damage can be caused by pressure wave impact or impact of missiles. The potential sources of shock waves are shown in the risk map of the area around the RID in Figure 7-1 and indicated with red marks and lines.

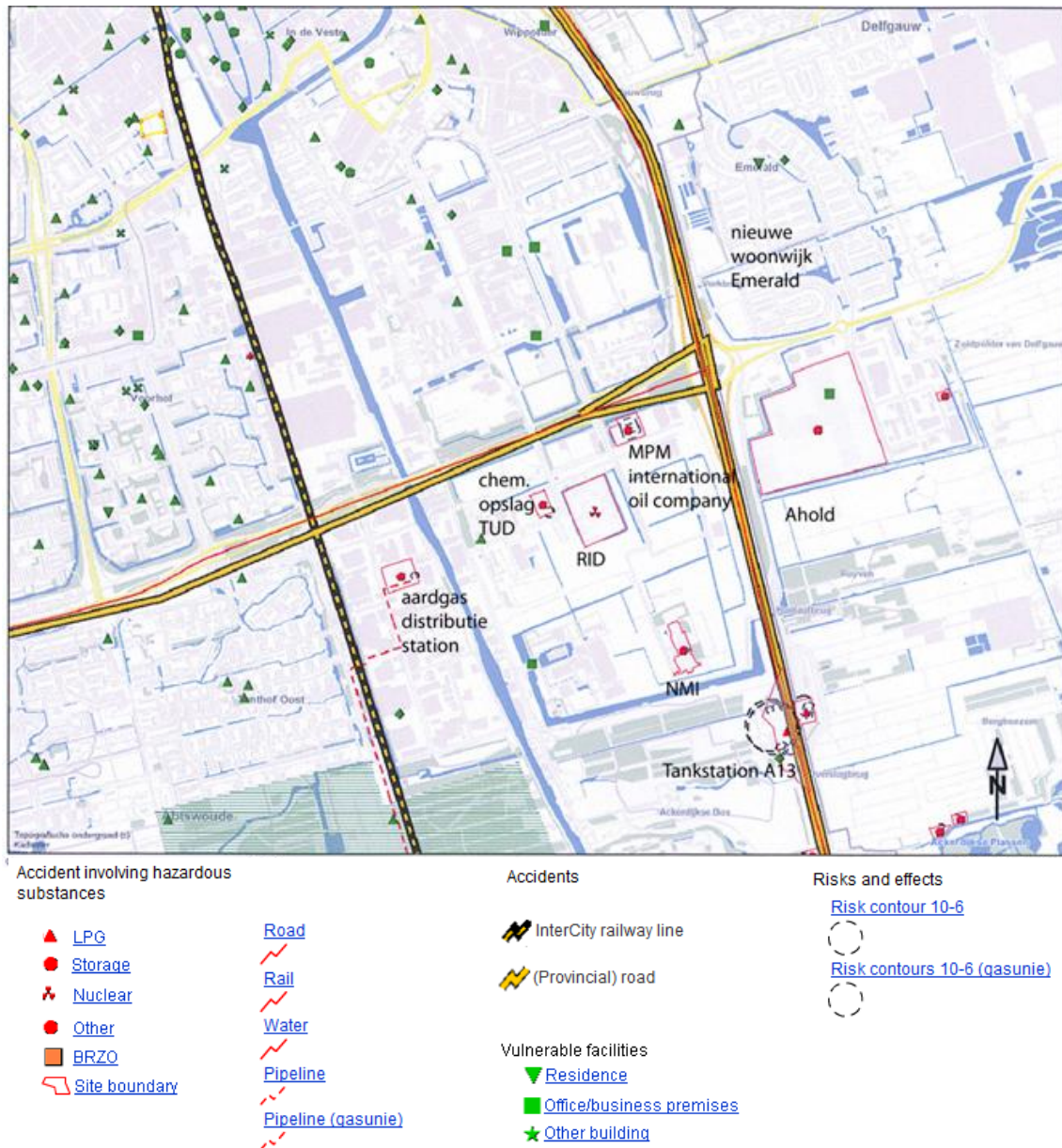

Figure 7-1: Risk map surroundings of RID

The risk map shows the risks of death for people ($10^{-6}/y$); the risk of severe damage to buildings is assumed to be much lower.

The risk map shows that external explosions may originate from:

- Gas distribution station (aardgas distributie station);
- Chemical Storage (chem opslag TUD);
- Oil Company (MPM international oil company);
- Production of chemicals (NMI);
- Petrol station (Tankstation A13);
- Distribution facility (Ahold, ammonia gas storage).

The circle around the petrol station along the motorway A13 indicates a risk contour (the contour does not include the RID). The risk contour of the other facilities are small and limited by the buildings themselves and therefore not always on the map. From the external storage locations, the chemical storage (chem opslag TUD) is closest to the reactor and has the largest amount of combustible substances.

Explosive or toxic substances may also be transported by the rail road Rotterdam-Den Haag (black yellow line at the left hand side of Figure 7-1), main roads N470 and A13 (at the right) and by ship at the Schie (at the left).

7.2.2 Potential consequences for the safety systems

The distance of the HOR buildings to the main gas pipeline is approximately 700 m. The legal standard for high pressure gas pipelines is a 10^{-6} risk contour which is at 5 meters from the pipeline. Because of the distance to the pipeline, the shockwave, due to an explosion of the main gas pipeline, will be strongly decreased and faded out within a distance of 700 m. The risk for containment damage due to an external explosion is therefore negligible.

In Figure 7-1 the 10^{-6} risk contours are shown for the storage facilities of chemicals. The contours do not cover the HOR site. The risk for damage of confinement and thus release of radioactivity is therefore negligible.

The 'Risicoatlas Spoor', published by the Ministry of Infrastructure and Environment (former Transport and Water Management) shows that the individual risk of transport by rail is $10^{-6}/y$ at a distance of less than 10 meters from the centre of the rail road. The distance to the HOR is approximately 1000 m. In case a leakage of explosive gas from a train does not explode directly, the possibility occurs that during specific weather conditions a cloud of explosive gas is driven by wind to the HOR site. This cloud of explosive gas might be ignited by for example the electrical systems at the HOR site. However this scenario falls within calculated risk contours, so the risk of this scenario will be very low ($< 10^{-6}/y$) at the given distance.

A gas explosion caused by an accident with a fuel truck may occur. The distance to the main road (N470) is approximately 300 m. No damage to the containment is to be expected due to an explosion at that distance. In case of leakage of explosive gas, it is not known if the concentration at the HOR site can exceed the lower explosion limit. However, due to the limited amount of explosive gasses to be transported by a truck, it is unlikely that an explosive mixture will be formed on the HOR site.

An explosion of gas on a local road near the HOR site could result in damage to the outbuildings. It is not known if the reactor building will be damaged, but it is unlikely that serious damage will occur (the reactor building is resistant against high pressure loads, as was calculated by Comprimo see chapter 4).

With concern to ship transportation, at this part of the Schie few shipping takes place and no chemical industry for supply is located up or downstream. Due to the distance of the Schie to the HOR, approximately 600 m, no effects of possible explosions from ships are to be expected.

In conclusion: because the building is not affected by external explosions, the basic safety functions will be maintained/ are not jeopardized.

7.3 Internal fire

7.3.1 General description of the event

The risk of an internal fire inside the containment is small due to the low amount of combustible inventory (low fire load, soundproofing material of the inner plates of the containment is unknown). In addition, all areas (inside and outside the reactor building) are equipped with fire detection systems. The system gives audible and visual alarms in the control room and is connected to the fire brigade RID (part of ERO). The fire brigade RID uses protective clothing, masks and manual fire extinguishing systems.

The insulation material in the containment, fireproof glass wool, is not in contact with the inner environment and placed between the steel wall of the reactor hall and the aluminum outer plates. On the inside, plates of soundproofing material are present that are made of a synthetic material. Their fire resistance is unknown.

Diesel fuel is stored outside the containment in the diesel power building. No other combustible materials are stored at the HOR site.

In the context of actualization of fire safety requirements (according to the current fire standards in buildings), a fire safety analysis is underway. For this an inventory of fire loads per room is made. Further actions on this topic are in progress.

7.3.2 Potential consequences for the safety systems

An internal fire can cause failure of electric cables, which can result in a loss of power (see chapter 5). In case of a large fire, safety systems can be damaged resulting in a fail safe mode of the safety systems. In this situation the pool stays intact. The reactor is scrammed and the residual heat will be removed by the pool water.

Due to the low fire load in the reactor building, the situation of a large fire is very unlikely.

Recommendation: investigate/determine the fire resistance of the synthetic plate material at the inside of the containment; perform a fire analysis from the viewpoint of nuclear risks.

7.4 External fire

7.4.1 General description of the event

External fires may originate from:

- Storage and use of combustible materials of organizations outside the HOR site;
- Trucks, trains and ships carrying flammable material on nearby transport routes.

Transport of flammable materials is covered in section 7.2 of this chapter (External explosion).

The fire load of the grass surrounding the buildings is so low that spreading of a fire to the HOR buildings via the grass is not possible. The HOR confinement is made of steel and has as such a very fire resistance.

A fire at the university chemical storage (Chem Opslag TUD) can cause a lot of smoke and sparks. Due to smoke formation personnel in the control room might be forced to leave, because this room cannot be isolated completely.

External fire causing "Loss of off-site power" is not to be expected as offsite power is realized through ground cables and not by overhead lines and an open switch yard.

7.4.2 Potential consequences for the safety systems

No consequences to the safety systems of the HOR are to be expected from fires coming from adjacent storage facilities or material transport. However unlikely (due to intervention measures of the fire brigade, see chapter 6), flying sparks may cause fire on the bitumen roofs of the control room and HOR outbuildings. Due to this, the control room may be heated up significantly causing damage to instrumentation and cabling. In practice, the reactor has been shut down a long time before the situation has worsened and emergency measures have been initiated (see chapter 6). In the ultimate case, the control room has lost all connections to instrumentations resulting in the loss of control and monitoring functions.

Due to loss of power, safety systems like RSA, BIS and RIS are “activated” and fall into their fail safe positions. This means that the reactor is made subcritical and the pool and reactor building are isolated. So the three basic safety functions reactivity control, confinement and cooling are ensured.

7.5 Airplane crash

7.5.1 General description of the event

In the initial plant design, Airplane Crash (APC) impact and fire has not been considered as a relevant load case since the site is located outside the direct influence range (flying zones) of commercial and military airports. However, from 2001, this event has been given consideration.

In case an aircraft crashes in such a way that the reactor hall is not affected, but only one or more of the other buildings, then the reactor will be shut down and kept intact. The affected buildings and their equipment will however be lost.

In the worst case, the aircraft crashes directly into the reactor containment and it is assumed that the reactor pool will be severely damaged and drained and (a part of) the contents of the core will be spread into the environment. So all the basic safety functions are lost.

7.5.2 Potential consequences for the safety systems

In the safety report an evaluation of an APC has been made based on the analysis of an APC on the BER-II reactor (also a ‘swimming pool’ research reactor) in Berlin, Germany. It was concluded that the consequences for the environment of the RID were limited. However, the APC analysis was not made specifically for the HOR.

In case of an APC on the HOR, the National Response Plan for Nuclear Accidents (Nationaal Plan Kernongevallenbestrijding) will come into force. This involves organizations like fire brigade, community health service (GGD) and police, with whom preparatory consultations have taken place. Also, Severe Accident Management actions will be initiated, to minimize the consequences for the surrounding area, as described in Chapter 6 of this report (Severe Accident Management).

Recommendation: Evaluation of the emergency plans which needs to be activated in case of an APC with core damage and release of radioactive material. For this, a HOR specific APC accident analysis should be performed in order to make reliable estimations of the consequences.

7.6 Toxic gases

7.6.1 General description of the event

Toxic gases may originate from:

- Toxic gases from the HOR site;
- Toxic gases from the surrounding companies;
- Toxic gases from rail, road and ship transportation. The chemicals could be released by a leakage, a fire or an explosion.

In the reactor building cylinders with non-toxic but potential suffocating gasses Helium, Nitrogen and Argon are present (50 liters, 200 bars). Outside the building a tank with 5 m³ Nitrogen at 3 bar is stored. This tank is located about 60 meters from the ventilation inlet.

In the other RID buildings, very limited amounts of toxic gasses are present in the labs.

In paragraph 7.2.1 the risk map shows the storage locations of chemicals and toxic gasses nearby the HOR site.

Chemicals released by ship, train and accidents on the main road do not pose a threat for the reactor operations. Due to the distance (see Figure 7-1) a potential toxic cloud will be significantly dispersed before arrival at the HOR site. A truck accident on the local road in front of the HOR site might cause a toxic gas cloud.

7.6.2 Potential consequences for the safety systems

An accident with toxic gases may pose a threat to the control room personnel, but will not threaten the plant systems.

As the HOR control room cannot be isolated, a toxic cloud could potentially incapacitate control room personnel. In that case, the HOR will continue to run as long as no malfunctions or resource shortages occur. Reactor power will decrease in time when the AIS is triggered (control rods stay in position). The AIS stops when a difference among control rod positions of more than 10% has been reached. Normally, the reactor will however be scrammed manually in case of a hazard situation. The residual heat of the reactor is removed by the pool.

7.7 Large grid disturbance

7.7.1 General description of the event

Large grid disturbances, including overvoltage, voltage interruption/short circuit and frequency transients, could cause damage to the main transformers and the electrical

systems behind it; in the worst case causing their permanent unavailability or causing damage to safety systems. Damage can also be caused by fire, see sections 7.3 and 7.4.

7.7.2 Potential consequences for the safety systems

For the HOR a situation of Loss Of Off-site Power (LOOP) or station black out (LOOP-SBO), as described in Chapter 5, does not threaten the fundamental safety functions confinement, cooling and reactivity control.

Pool isolation and containment isolation valves close in case of system failure due to loss of electrical power. In these positions the confinement function and cooling function are met. The control rods fall into the core when power is interrupted and the magnetic force, keeping the rods in position, is cut off. The reactor is brought in a subcritical state and reactivity is controlled.

7.8 Failure of systems by introducing computer malware

7.8.1 General description of the event

In this report, “failure of systems by introducing computer malware” implies accidental invasion of malware in the HOR computer systems. Malware, short for malicious software, is software (or script or code) designed to disrupt computer operation, gather sensitive information, or gain unauthorized access to computer systems. It is a general term used to describe any kind of software or code specifically designed to exploit a computer, or the data it contains, without consent. The expression is a general term used by computer professionals to mean a variety of forms of hostile, intrusive, or annoying software. Malware includes computer viruses, worms, Trojan horses, spyware, dishonest adware, most rootkits, and other malicious programs. This accidental invasion could be accomplished either by users of the HOR, or by those with an internet connection.

The safety related systems are controlled by the RPS which uses computerized and non-computerized electronic hardware, like EEPROM (Electrically Erasable Programmable Read-Only Memory) and hard-wired systems. Irradiation experiments and other experiments with radioactive material are often equipped with PCs, but these are never connected to the facilities safety systems.

The electrical main switchboards of the HOR (low voltage room) are equipped with a computerized parameter control and monitoring system. It is not connected to an external network. Its control capability is locked, but can be unlocked with special keys.

The HOR control room is equipped with a process computer. It is used for presentation and registration of process variables and for the automatic control of the reactor power. The HOR Computer is connected to a special dedicated HOR network that can be accessed from one other TUD building outside the RID for remote monitoring. Theoretically it could be accessed

from inside, and false information could hypothetically enter through this access. This might cause confusion under the control room personnel, however important process parameters are also available on the reactor instrumentation directly. There is no connection to the HOR's reactor protection system, see Figure 7-2.

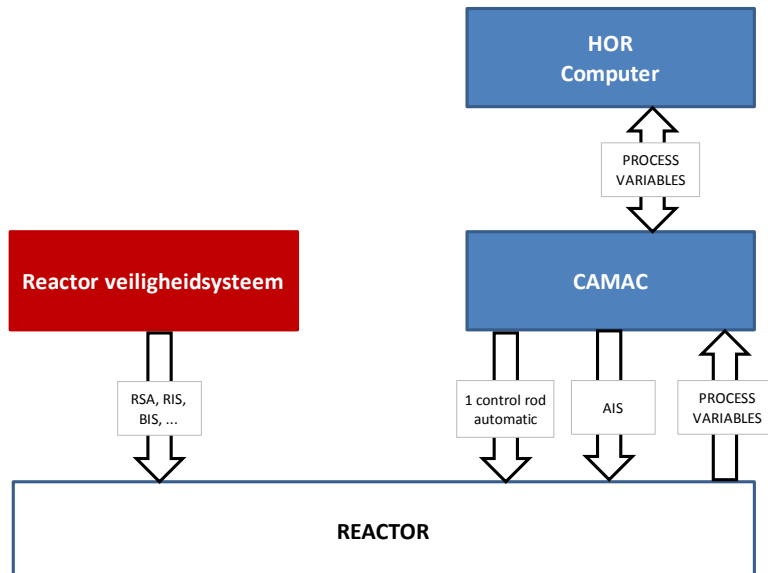

Figure 7-2: Relation of HOR Computer to the reactor protection system

The independent CAMAC system is used as data acquisition and interface system between the HOR computer and the reactor and it houses the AIS system.

7.8.2 Potential consequences for the safety systems

The safety systems of the HOR are controlled by computerized and non-computerized electronic hardware. The reactor protection system is independent of the HOR computer. Failure or spurious actions of this computer cannot result in a threat to the fundamental safety functions. The experiment information computers are solely supportive for plant control: they only show information, but does not control plant systems. All this, in combination with an intact pool, offers sufficient protection on forehand for the reactor and its safety systems.

Theoretically the process information system in the HOR control room could be accessed from inside and false information could hypothetically enter through this access. This might cause confusion under the control room personnel. However, according to their procedures they will only take action if the information is confirmed by readings of the analogue instrumentation on the control console and panels.

7.9 Internal flooding

7.9.1 General description of the event

By definition internal floods are floods that originate from systems that are part of systems that constitute the HOR operations. In the reactor building (including pipe basement), this might originate from leakage of cooling water, demin water systems or storage tanks. The public water supply system is a potential source of flooding in all buildings.

The design criteria to mitigate internal flooding and their consequences focus on:

- Appropriate design: this means that by plant layout and system design, mitigation is effective e.g. by:
 - proper design to prevent leakages;
 - flow paths to accumulation areas;
 - drain systems;
 - protecting electrical systems against water ingress when submerged or wetted;
 - thresholds, protecting other areas.
- Procedures: normal operating and/or emergency operating procedures will support/guide operator actions to control internal flooding;
- Detection systems: means for detection of leakage or flooding are available. For leakage detection these means can refer to system process parameters such as the level, flow, temperature and pressure of the water. For detection of flooding, means can be based on flow or mass detection of drain systems or water level indication in (assigned) accumulation areas.

Identified water sources

Water originates from bulk stored inside or from systems having large mass flow capacity while externally supplied. (Large) water volumes or supplies inside the different buildings are:

The reactor building:

- Pool;
- Storage tanks in the basement;
- Primary cooling water system (pipe basement);
- Secondary cooling water system (pipe basement);
- Public water supply system (including fire fighting systems).

The pump building:

- Secondary cooling water system;
- Public water supply system.

Other buildings:

- Public water supply system (including fire fighting systems).

Affected areas

Reactor building-basement

In case of a leakage of a storage tank or the public water supply system in the water treatment room, which is located in the basement (Figure 7-3), water is collected in drains via trenches in the floor. The water is pumped to collection tanks. In case of severe leakage, for instance of the large tank T1 (250 m³), water collects at the floor when the collection tanks are fully filled and partly flows to the adjacent building part, Wing 4. The water height on the floors will be a few centimetres. Electrical component enclosures are positioned at a height from 30 cm. Several water detection systems are installed in this water treatment room, giving only alarm (no automatic actions).



Figure 7-3: Water treatment room in the basement

In case of leakage of the primary or secondary cooling water system in the pipe basement (Figure 7-4), the contents of the pipe system will collect at the floor and pumped (partly) away by a drain pump. The leakage of the primary system is limited due to the automatic closure of the pool isolation valves, which is actuated when pool level decreases (actuates at ~ 7cm below maximum water level). Leakage of the pool liner is detected by collecting vessels (inspected weekly). The level of the possible remaining water on the floor is limited (maximum in order of centimeters). The primary pump is positioned at a height of 20 cm.

In case of severe leakage of the pool, the pipe basement is flooded. The water flow path from the pipe basement is via the pipe penetrations to the pump building of the secondary system.



Figure 7-4: Pipe basement

Reactor building-ground level

Due to leakage of water from the public water supply system or the pool, water collects at the floor of the reactor building. The wall and doors are watertight. Penetrations to the basement are gastight so water does not flow to the basement.

Pump Building

In case of water leakage, the water collects at the floor and flows through small openings to the environment. However water inside the pump building (both secondary cooling water and water from the public grid) does not contain any radioactivity.

Reactor outbuilding

In the low voltage room (laagspanningsruimte), Figure 7-5, no water supply system is located. Due to water leakage of the public water supply in adjacent rooms the floor might be wetted, but water flows to lower levels in-and outside the building, and a high water level

will not be reached to cause a failure of power supply or loss of instrumentation of the reactor protection system.

Reactor outbuilding-Control room

In a side area of the control room tap water is available. Due to water leakage of the public water supply system the floor of the control room may be wetted. Water flows away via openings under doors to the roof or via the staircase to lower floors. The panels in the control room are raised and cable penetrations to the control room are leak tight.

7.9.2 Potential consequences for the safety systems

Due to internal flooding the safety systems are not affected. The potential amounts of water causing internal flooding are limited and cannot cause high water levels (up to a few centimetres) of the basement and ground floor of the reactor building, except for the case of severe pool leakage. In that case the pipe basement is flooded to the level of the pipe penetrations of the secondary system. The primary pump fails.

The water content in the pipe basement, in case of severe pool leakage, does not influence accident management actions with regard to the filling of the large storage tank T1 (T1 is connected to the pool and can be used to fill the pool by means of levelling). In these accident management actions a pipe has to be connected to T1, which is a manual action, to fill T1 with water from the fire fighting system (hydrant leading). For this, the pumps in the water treatment room (the basement in which T1 is located) have to be used. These pumps are positioned at a height of 40 cm and are not flooded. In case of failure of these pumps, T1 can be filled in the manhole at the top of T1 via fire hoses.

Instrumentation and electrical cabinets in the control room and low voltage room are not threatened by a rupture of nearby public water supply systems.



Figure 7-5: Electrical cabinets in the low voltage room at ground level

7.10 Blockage of cooling water inlet

7.10.1 General description of the event

Cooling water blockage is defined as blockage of the flow of the secondary cooling system. This results in loss of ultimate heat sink.

7.10.2 Potential consequences for the safety systems

In chapter 5 LUHS is described.

List of tables

Table 1-1: Buildings in the neighbourhood of the HOR.....	28
Table 1-2: Main characteristics of the HOR	31
Table 2-1: Comparison between MMI and Richter scale, valid at epicenter of natural earthquake	63
Table 6-1: Consignees outside normal operation	113
Table 6-2: Impairment of rooms or buildings due to external hazards.....	121

List of figures

Figure 1-1 : Location of the RID site	27
Figure 1-2 : View of RID site	28
Figure 1-3 : levels at RID site, with ground or 'MAAIVELD' level at -1.2 m NAP.....	29
Figure 1-4: Site map of the RID.....	30
Figure 1-5: Side view of the reactor pool.....	33
Figure 1-6: Standard HOR-LEU core.....	34
Figure 1-7: Spent fuel positions: in the pool.....	35
Figure 1-8: the heat removal system.....	37
Figure 1-9: lay-out of reactor hall including the control room building ('regelkamer', RK)	38
Figure 1-10: signals of the reactor protection system	40
Figure 1-11: the reactor containment.....	42
Figure 1-12: the water clean-up and make-up system	43
Figure 1-13: Diagram of the electrical power system	44
Figure 1-14: Overview of the beam tubes.....	46
Figure 1-15: Construction of a beam tube	46

Figure 1-16: Pipe basement	54
Figure 1-17: electric power supply equipment.....	60
Figure 2-1 : Overview of tectonic plates; source: KNMI.....	62
Figure 2-2: Earthquakes in the Netherlands, 1904-2004, magnitude in Richter Scale: source KNMI	64
Figure 2-3: Seismic risk map of the Netherlands; left hand: intensity (EMS); right hand: peak acceleration (zones A, B, C and D , respectively 0.1, 0.22, 0.5 en 1.0 m/s ²).....	65
Figure 3-1: Ground level around Delft (source): het Actueel Hoogtebestand Nederland (AHN).....	79
Figure 3-2: Ground level around the HOR site (source: Het Actueel Hoogtebestand Nederland (AHN) detail	80
Figure 3-3: dijkkring 14, rode lijn; source: Coordinatieplan dijkkring 14, RWS.....	81
Figure 3-4: Worst case case scenario North Sea; source: Coordinatieplan dijkkring 14, RWS	83
Figure 3-5: Worst case scenario River: source: Coordinatieplan dijkkring 14, RWS.....	84
Figure 3-6: Heights of Safety relevant systems and structures.....	86
Figure 5-1: Diagram of the electrical power system	100
Figure 6-1: Complete Emergency Response Organization (ERO) from RID (former IRI)	112
Figure 6-2: Map for emergency planning of Fire Fighters	115
Figure 6-3: Connection between Emergency Plans for the HOR	117
Figure 7-1: Risk map surroundings of RID	133
Figure 7-2: Relation of HOR Computer to the reactor protection system.....	140
Figure 7-3: Water treatment room in the basement.....	142
Figure 7-4: Pipe basement	143
Figure 7-5: Electrical cabinets in the low voltage room at ground level.....	144

Appendix A Equipment of auxiliary systems

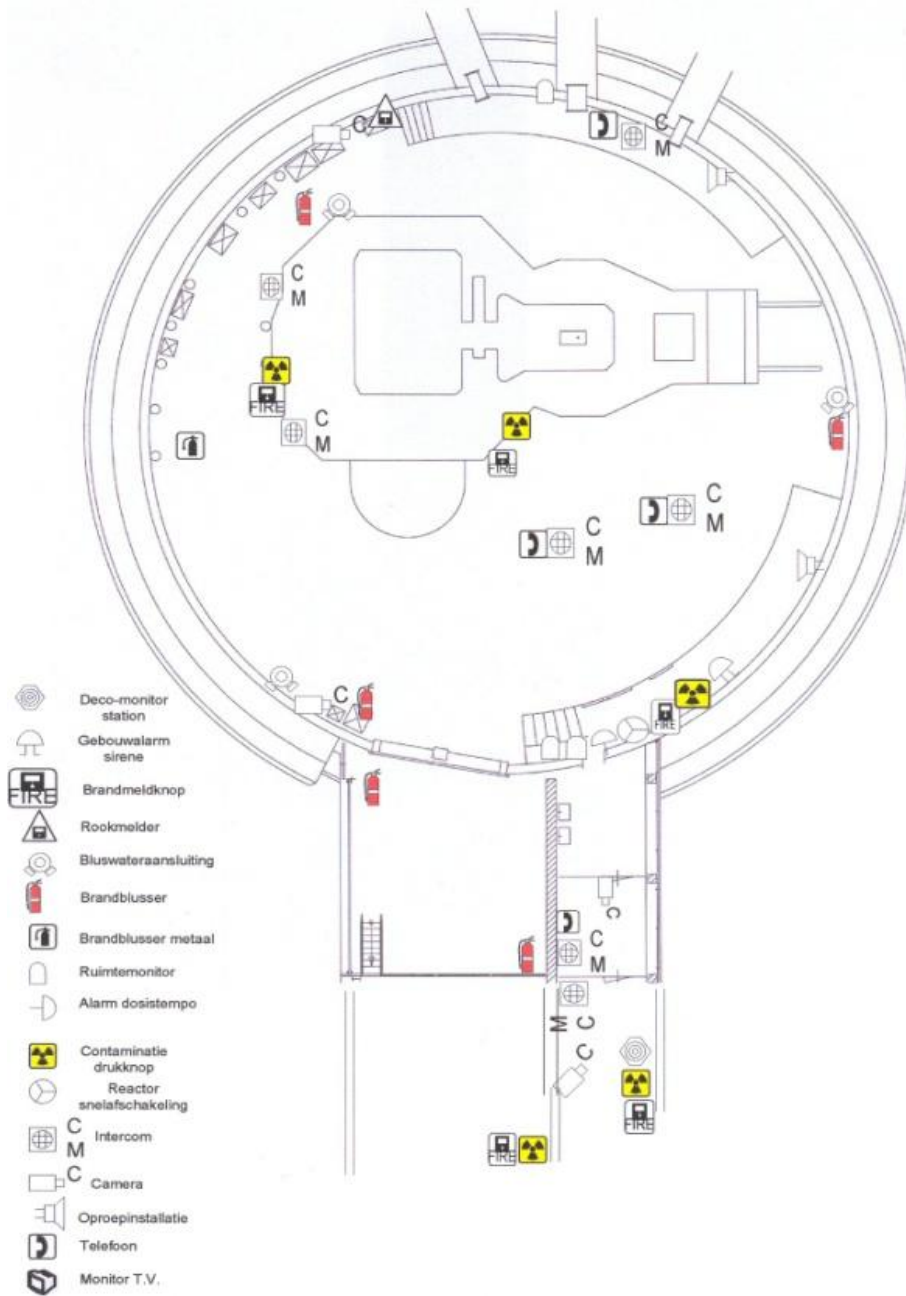

Figure A-1: Equipment at elevation +0 meter

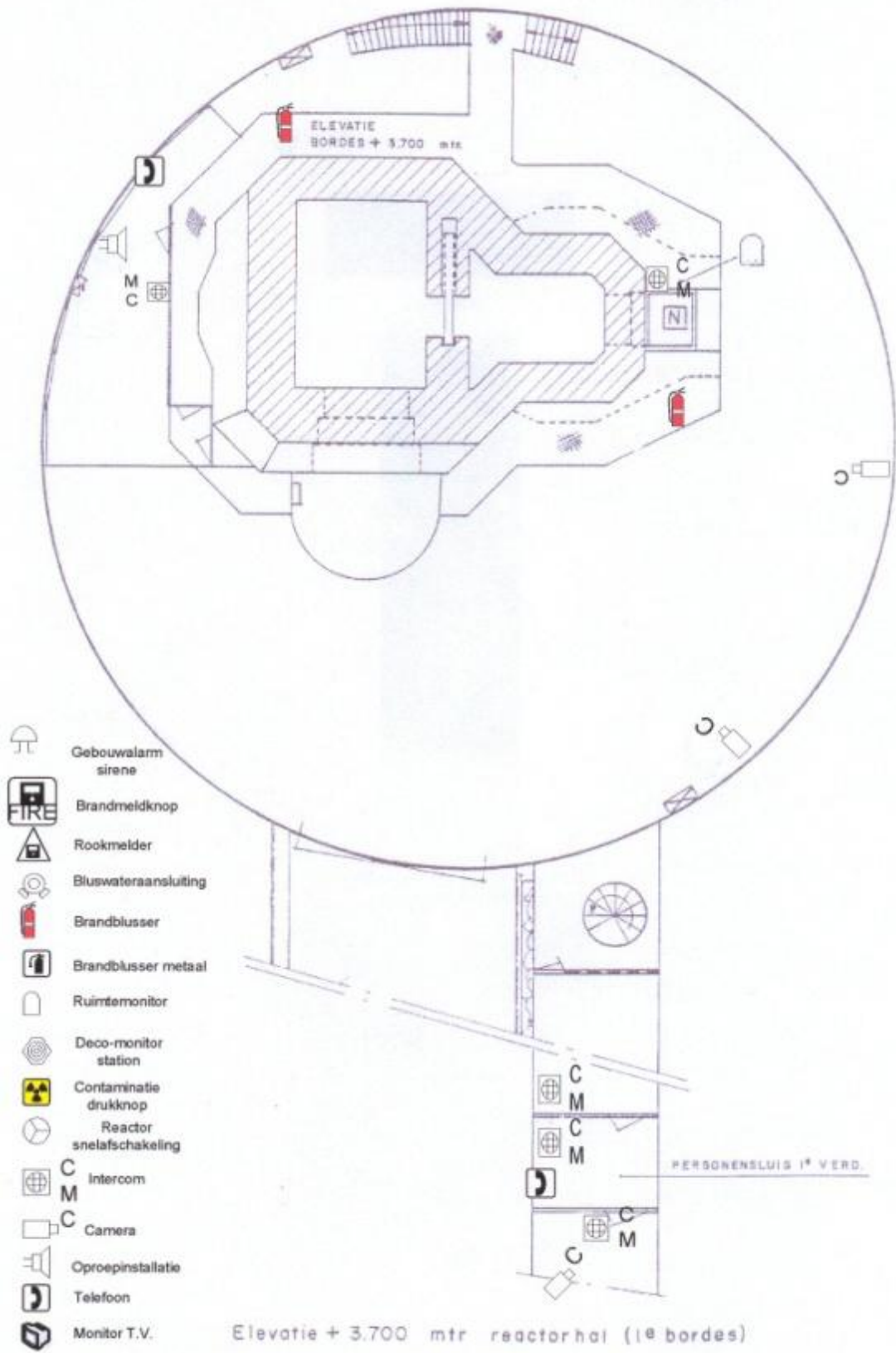

Figure A-2: Equipment at elevation + 3.7 meter

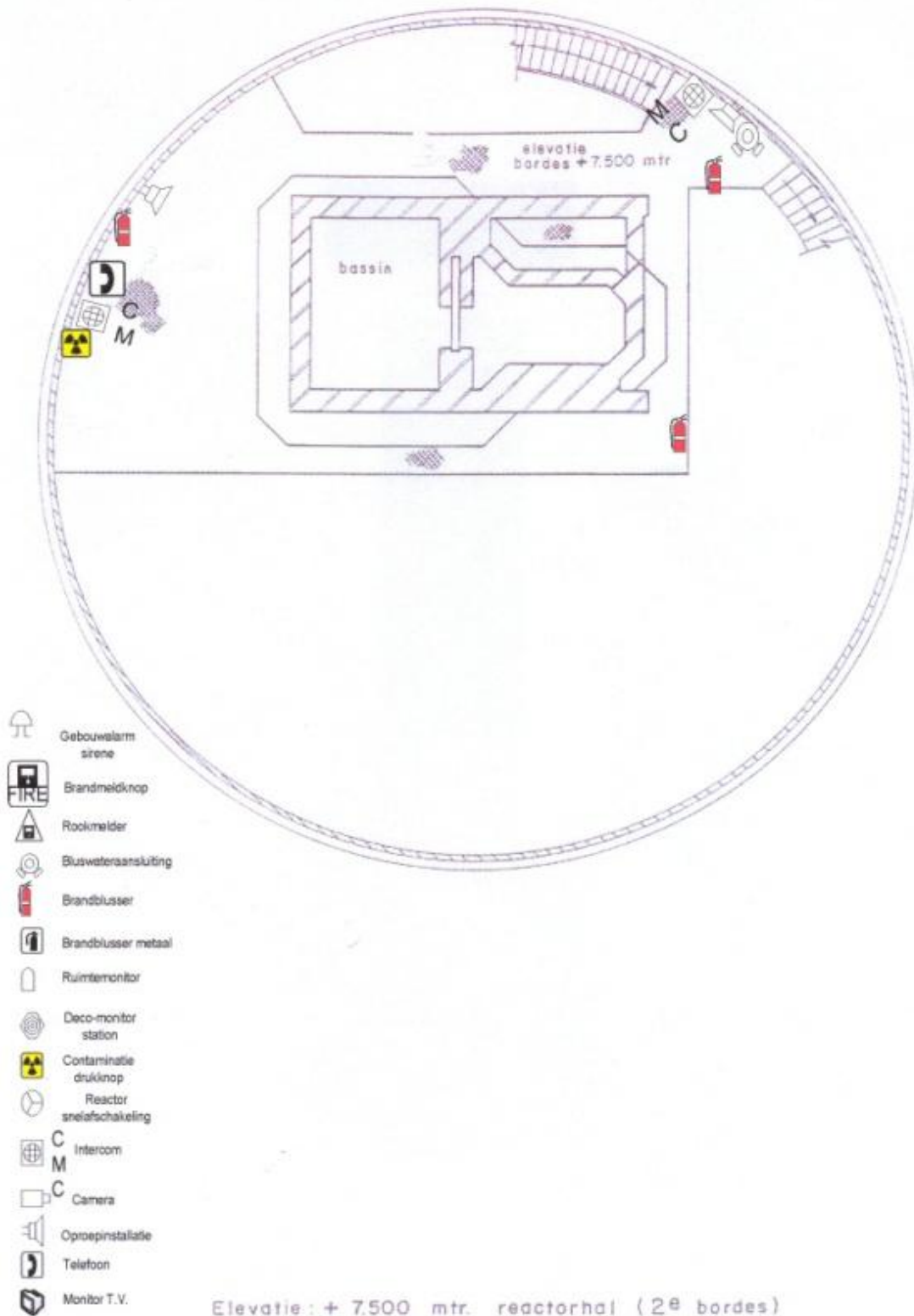

Figure A-3: Equipment at elevation +7.5 meter

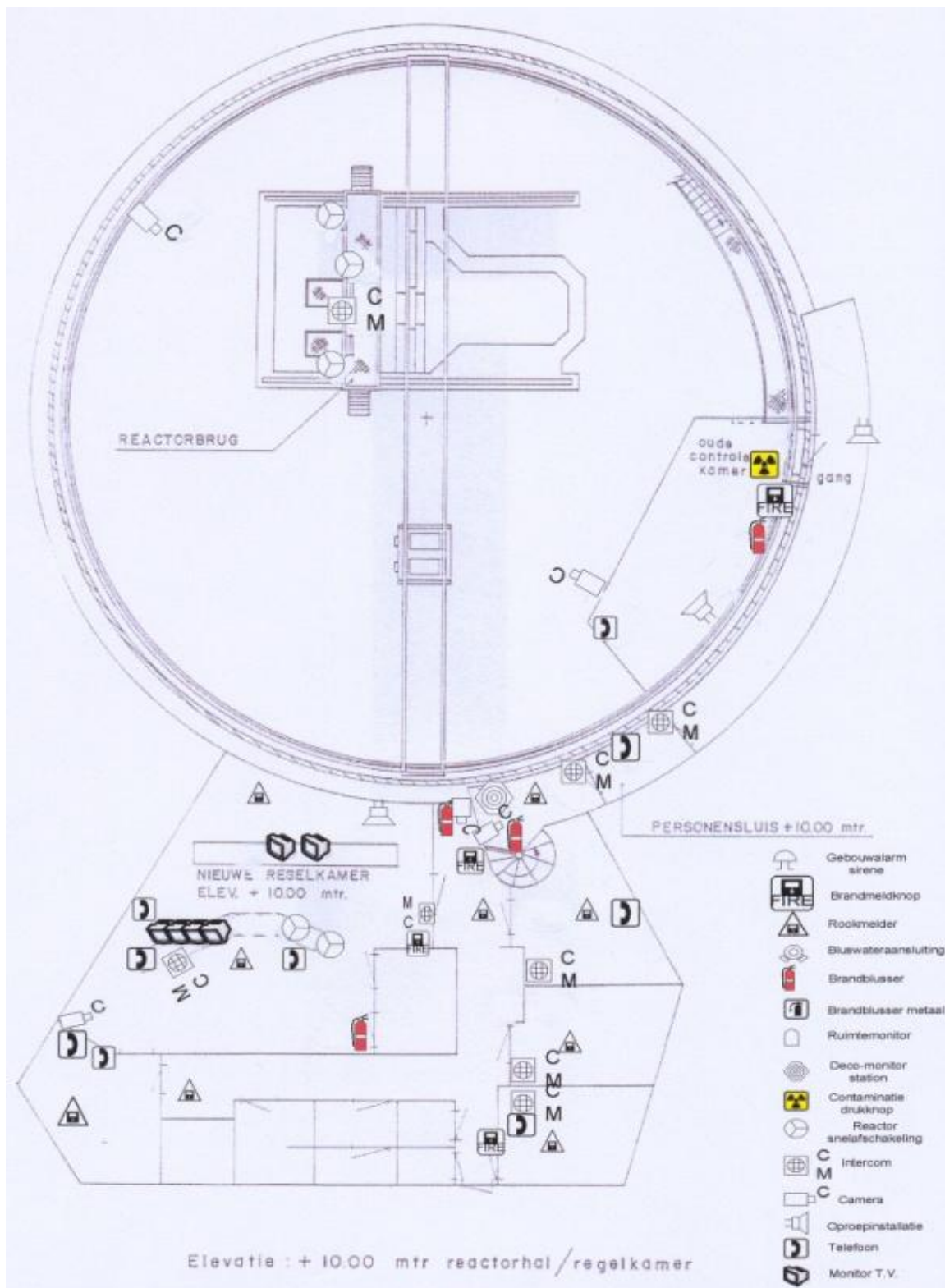

Figure A-4: Equipment at elevation +10 meter

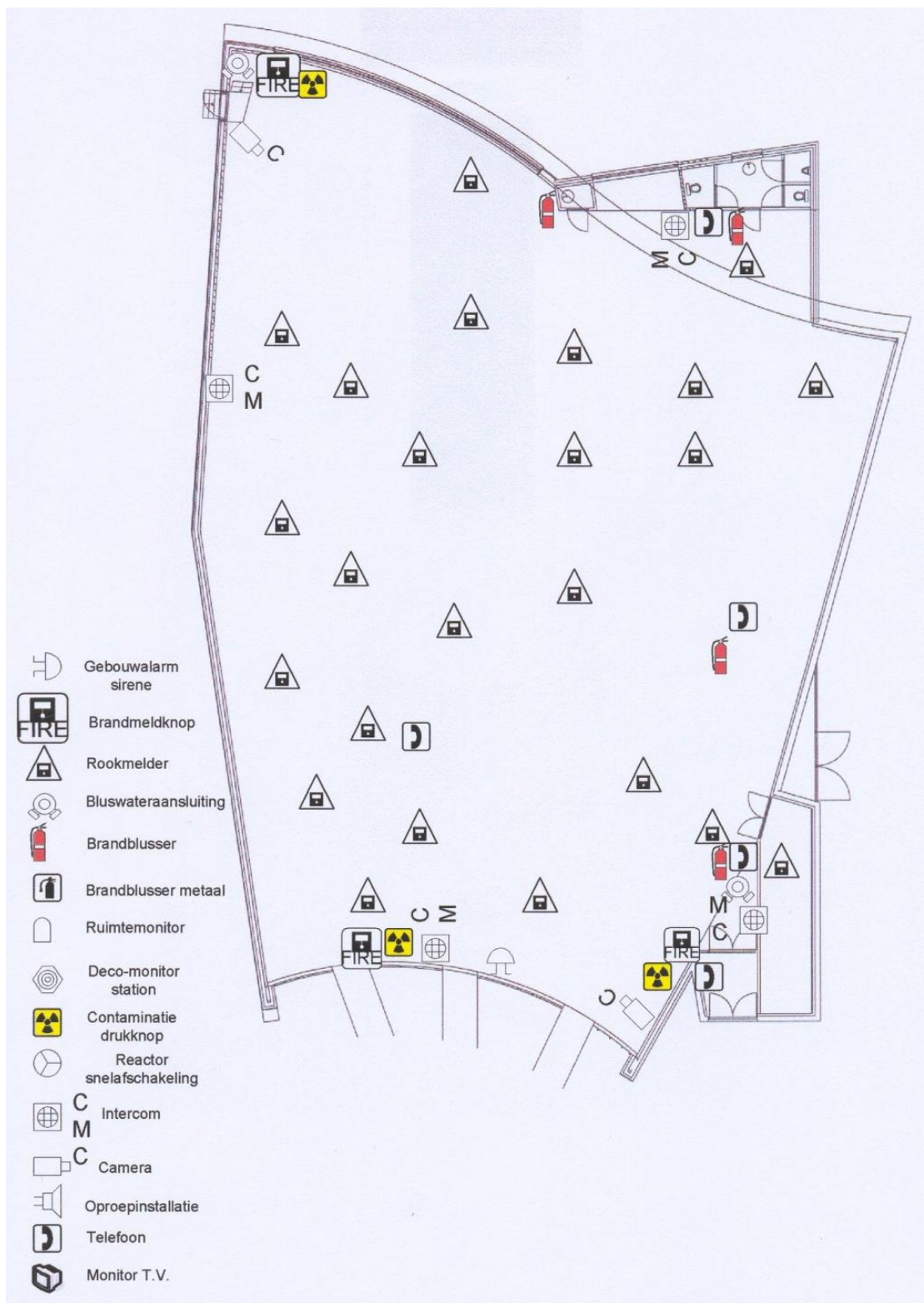
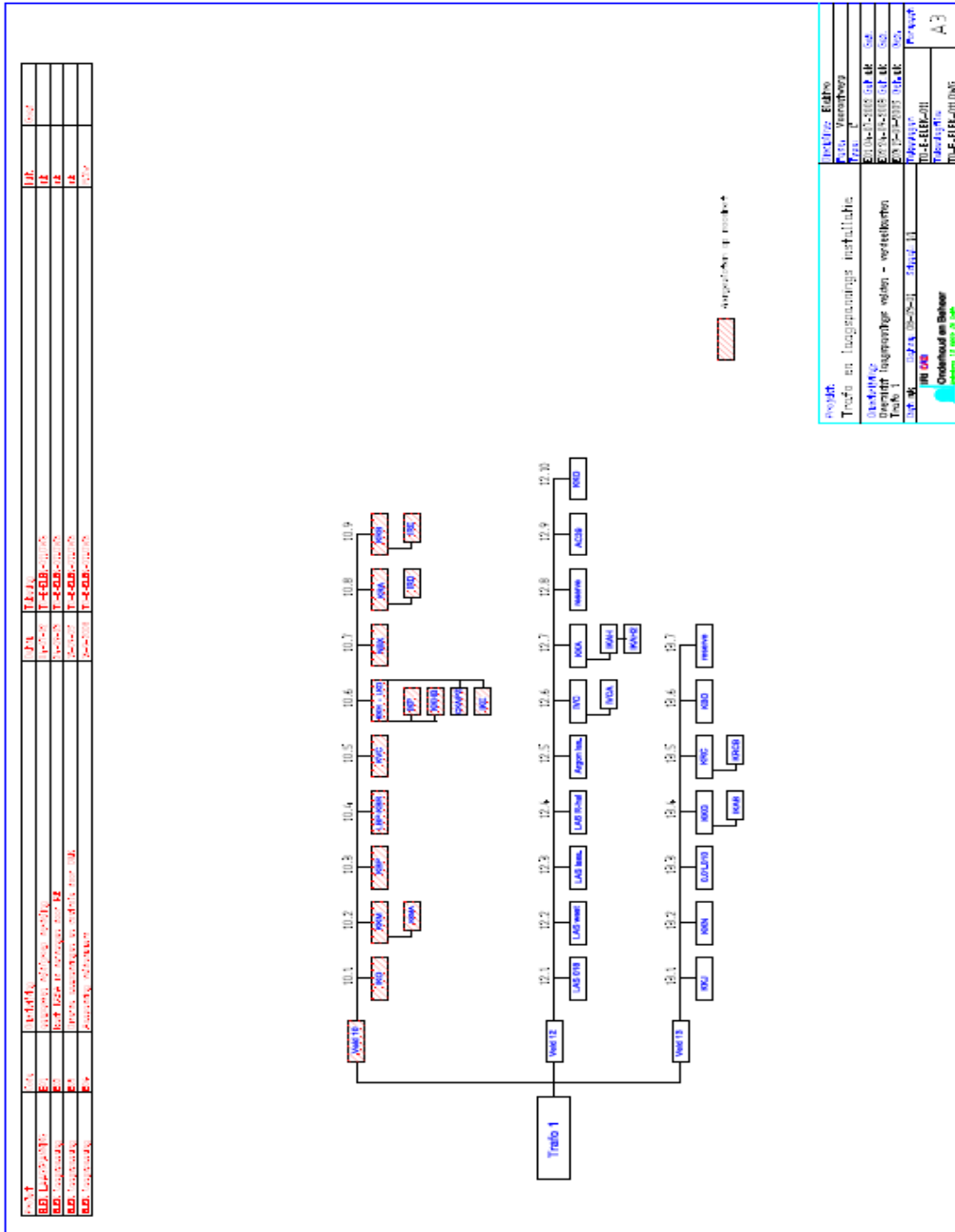

Figure A-5: Equipment in auxiliary building

Appendix B Electrical power system

Line diagrams



Project:	De Nieuwe Eilanden
Plaats:	De Nieuwe Eilanden
Opdrachtgever:	De Nieuwe Eilanden
Opdracht:	De Nieuwe Eilanden
Opsteller:	De Nieuwe Eilanden
Controleur:	De Nieuwe Eilanden
Uitgever:	De Nieuwe Eilanden
Datum:	De Nieuwe Eilanden
Bladzijde:	De Nieuwe Eilanden
Totaal bladzijden:	De Nieuwe Eilanden
Uitgever:	De Nieuwe Eilanden
Datum:	De Nieuwe Eilanden
Bladzijde:	De Nieuwe Eilanden
Totaal bladzijden:	De Nieuwe Eilanden

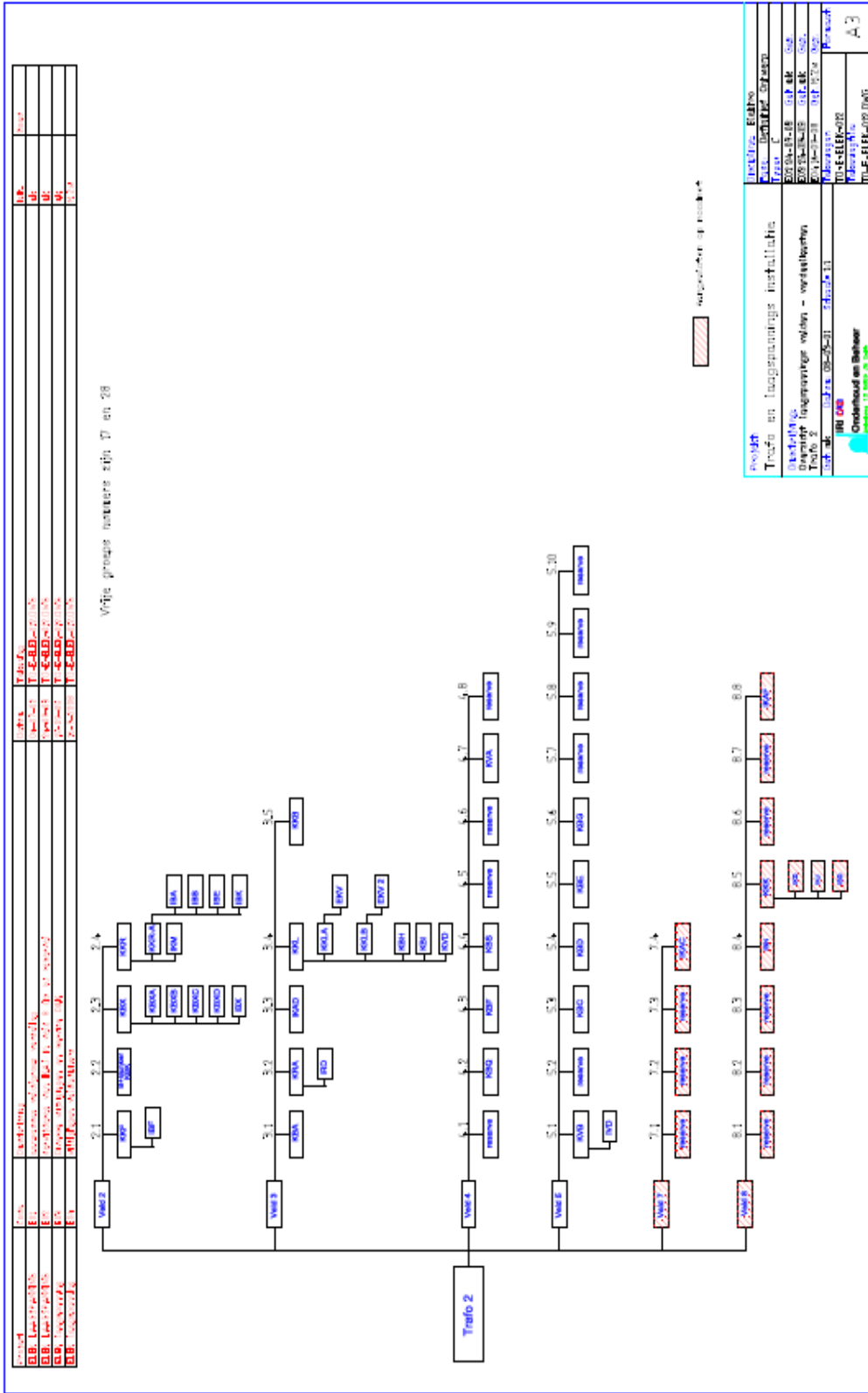

Code	Naam	Code	Naam	Code	Naam
T. 1	07-01-01	T. 2	07-01-02	T. 3	07-01-03
T. 4	07-01-04	T. 5	07-01-05	T. 6	07-01-06
T. 7	07-01-07	T. 8	07-01-08	T. 9	07-01-09

Code	Naam	Code	Naam	Code	Naam
T. 1	07-01-01	T. 2	07-01-02	T. 3	07-01-03
T. 4	07-01-04	T. 5	07-01-05	T. 6	07-01-06
T. 7	07-01-07	T. 8	07-01-08	T. 9	07-01-09

Code	Naam	Code	Naam	Code	Naam
T. 1	07-01-01	T. 2	07-01-02	T. 3	07-01-03
T. 4	07-01-04	T. 5	07-01-05	T. 6	07-01-06
T. 7	07-01-07	T. 8	07-01-08	T. 9	07-01-09

Code	Naam	Code	Naam	Code	Naam
T. 1	07-01-01	T. 2	07-01-02	T. 3	07-01-03
T. 4	07-01-04	T. 5	07-01-05	T. 6	07-01-06
T. 7	07-01-07	T. 8	07-01-08	T. 9	07-01-09

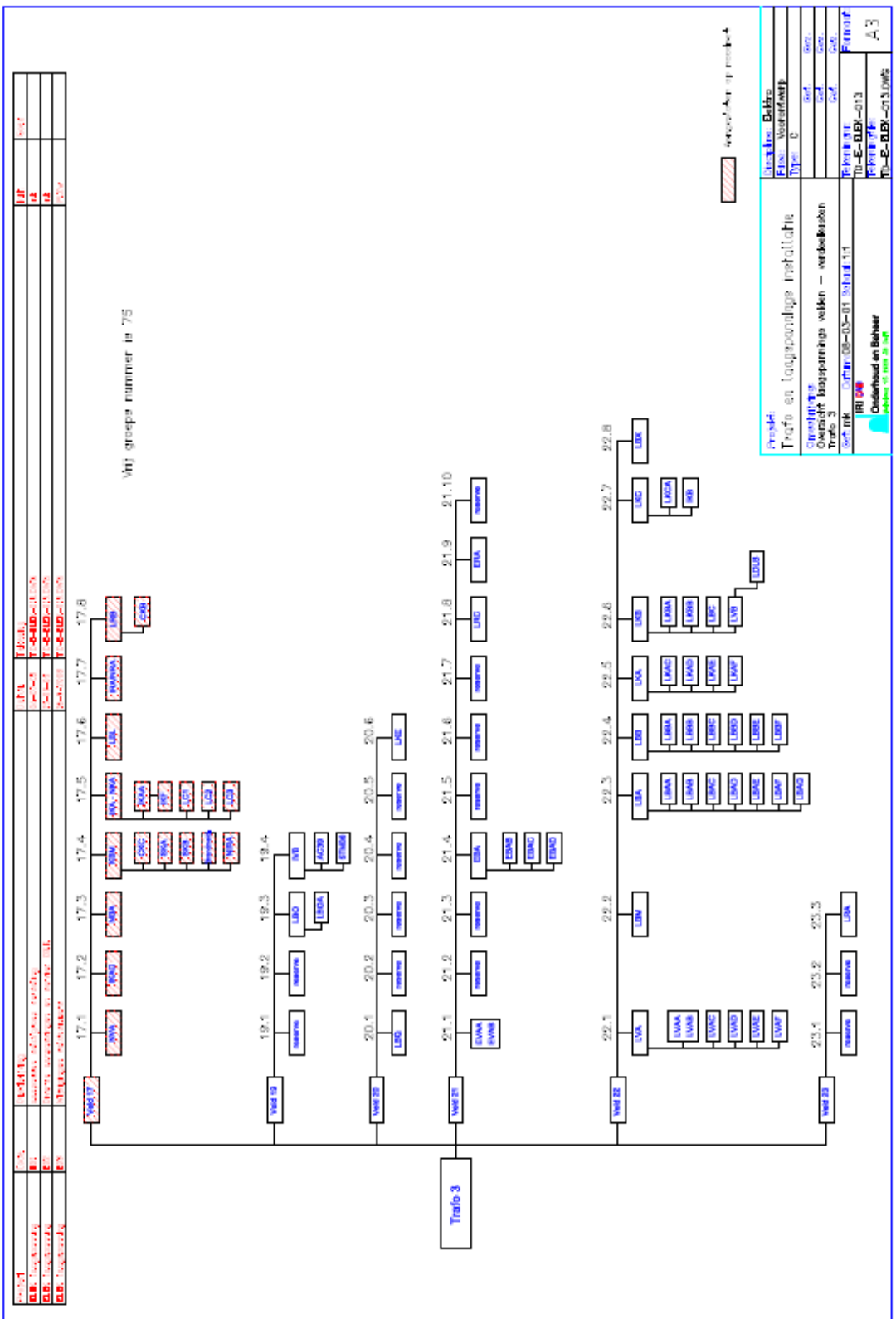

Appendix C Back-up power consumers

Kast trafo-1	Functie
IKF	Ionenwisselaar V1/V2
IKO	besturing perslucht/vacuüm en CV inst.
KKM	Noodverlichting oostvleugel / regelkast IKAJ en IKAK / voedingen versnellerruimte
KKMA	Is regelkast IKAK t.b.v. RA en MIRA putpomp in oostvleugel
IKAJ	Regelkast t.b.v. luchtbehandeling versneller en labs nieuw oost
KBP	Vorstpomp P3-2MW + niveau signalering koeltorens.
LBP-KBR	Noodverlichting vleugel 1 en 2 / hydrofoor vleugel 1 en 2 / ser ruimtes vleugel 1 en 2
KVC	Inbraakcentrale regelkamer + reactorhal / diverse krachtaansluitingen vleugel 0 1e verd.
KKH-LKD	Brandmeldcentrale / omroep- ontruimingsinstallatie / 3x MIRA putpompen / SER B
IKP	besturing gemeentewater druk verhoging gebouw
KKHB	Vervallen
CKA-PZI	Instrumentatie kast personen zoek installatie (pagersysteem)
IKE	Storing signalerings paneel in waterbehandeling
NBX	Nood verdeelkast t.b.v. experimenteerhal.
KRA	Bassindeur t.b.v. reactorbassin
KRB	Koelmachine AC-46 t.b.v. lbh regelkamer complex en HOR paneel / voeding voor IRE
IRE	Regelkast t.b.v. lbh regelkamer complex en HOR paneel

Kast trafo-2	Functie
IBN	besturingskast noodgenerator.
KKK	Diverse RA en MIRA pompen / SBD meetstation terrein
IKD	besturing putpomp hergebruik systeem
IKJ	regeling koelwater systeem gebouw
IBD	besturing koelcel
IKAF	besturingskast CV ketels, branders en pompen.
IKAC	Regelkast t.b.v. luchtbehandeling noord-, zuid- en oostvleugel.

Kast trafo-3	Functie
NVA	Noodverl. vleugel 0 1e verdieping / noodverl. personensluis / verl. HOR archief
IKT	Regelkast t.b.v. luchtbehandeling oost vleugel en dierenlab
NBA	Noodverlichting algemeen / MER
NKB	Diverse camera's / diverse netwerk patchkasten
NKB-A	Diverse beveiligingsinstallaties loge / toegangscontrole
CKC	instrumentatie kast Intercom (loge) systeem buiten hek en buiten deuren + BHO kast
SKA	kast tbv camera's en monitoren portiers loge
SKB	Besturingkast buiten hekken
Brandmeld	Brandmeldinstallatie
NIRA	Pagerrek
IRA/NRA	Hal alarm / subkast inbraakbeveiliging / verlichting bovenkrans / stelstaafmotoren
IKA/NKA	Voeding voor ICAA / IKAG / LC1 / Noodverlichting algemeen / Gasdetectie
ICAA	besturings kast bassinwater transport- zuiverings- hergebruikstestem
IKAG	besturingskast demiwater aanmaakstestem en registratie apparatuur
IKF	verplaatst naar trafo-1 veld 4.3
LC1	besturingskast luchtsluis beganegrond, en voeding voor bovensluis en personensluis
LC2	besturingskast luchtsluis verdieping
LC3	besturingskast personensluis verdieping
LRB	Noodverlichting regelkamer / HOR paneelkast 3, 4, 5 en 6, HOR computer / Lessenaar
	in regelkamer / Intercom installatie HOR / Camerasysteem reactorhal en regelkamer
CKB	instrumentatie kast intercom installatie HORB
LBL	MER

Appendix D Assessment of heat removal capacity of the pool

This appendix details the assessment of the decay heat removal capacity of the pool of the HOR for the situation that decay heat of the core and of the spent fuel that is stored in the pool are absorbed by the pool water.

The emphasis of this assessment lies on boil-off of the pool water because an indication is requested of its availability in time as an alternate heat sink. This means that, conservatively, heat-up of the pool water is neglected.

Decay heat curve of the core is provided by RID. This curve is also used for the spent fuel.

Both contributions are assessed in the following way:

- For the decay heat of the core, the most severe situation is that the reactor will be shut down at the moment it is operated at maximum power, namely 3 MW;
- For the spent fuel the following applies:

Since 2005 every year 3 elements of the core are replaced by fresh ones. The spent fuel elements are stored in the pool. The number of spent fuel elements almost equals one core. On average these elements have operated at 2 MW, as this is the usual power level the HOR is operated at. As this exchange is performed in sequence of approx. 4 months it is assumed that conservatively, the heat production of these 24 stored elements equals the production of a core that is operated at a $\frac{3}{4}$ level of the 2 MW core. This means that for decay heat calculation 1.5 MW is the starting point.

For the assessment of the heat dissipated into the pool a virtual core power at shut down of 4.5 MW is assumed. Figure D-1 shows the decay heat curve for this situation.

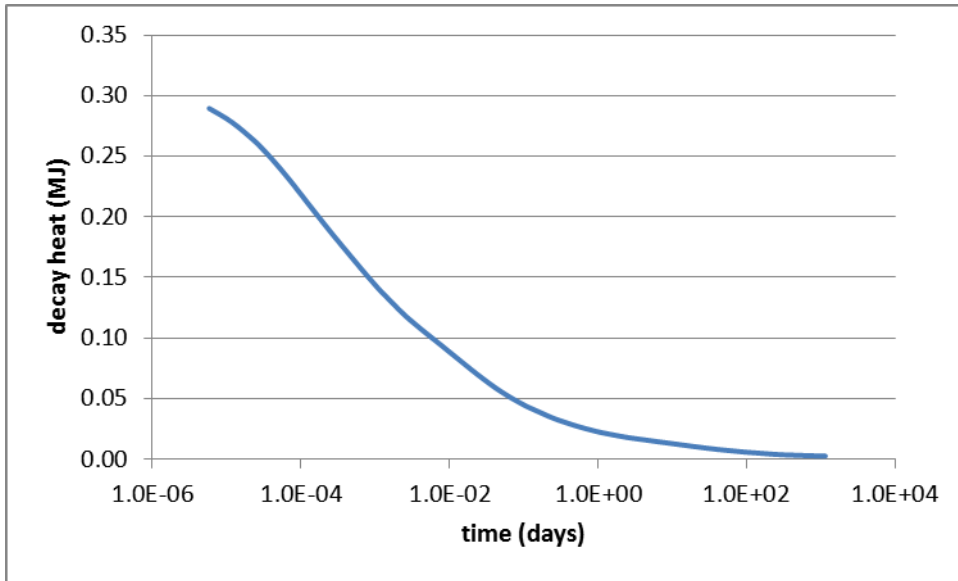

Figure D-1: decay heat dissipated into the pool of the HOR as function of time.

Based on this heat production the amount of water that is needed to remove this heat by boiling only is calculated. Figure D-2 shows the results. From this figure it can be concluded that after approx. 3 year 160m³ of pool water is boiled-off.

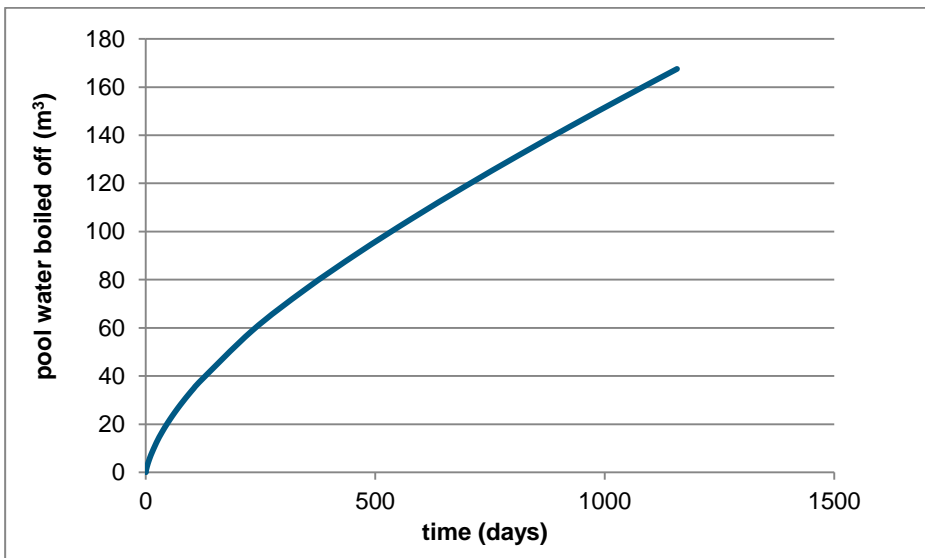

Figure D-2 : Amount of pool water boiled of as function of time (adiabatic conditions).